



Printer/Scanner Unit Type 2105

Operating Instructions Scanner Reference



-
- 1 Network Scanner
 - 2 Preparations for Use as a Network Scanner
 - 3 Setting Originals
 - 4 Sending Stored Scan Data by E-mail
 - 5 Using the Network Delivery Scanner Function
 - 6 Using the Document Server Function
 - 7 Using the Network TWAIN Scanner Function
 - 8 Appendix

Introduction

This manual contains detailed instructions on the operation and maintenance of this machine. To get maximum versatility from this machine, all operators should carefully read and follow the instructions in this manual. Please keep this manual in a handy place near the machine.

The scanner function is available when the Printer/Scanner option is installed in the machine.

Warning:

Use of controls or adjustment or performance of procedures other than those specified in this manual might result in hazardous radiation exposure.

Two kinds of size notation are employed in this manual. With this machine refer to the metric version.

Manuals for This Machine

The following manuals describe the operational procedures of this machine. For particular functions, see the relevant parts of the manual.

Note

- The manuals provided are specific to machine type.
- Adobe Acrobat Reader is necessary to view the PDF file manuals.
- Two CD-ROMs are provided:
 - CD-ROM 1 "Operating Instructions for Printer / Scanner"
 - CD-ROM 2 "Scanner Driver & Document Management Utilities"

❖ **General Settings Guide**

Provides an overview of the machine.

It also describes System Settings (such as paper trays and user codes settings), Document Server functions, and troubleshooting.

❖ **Network Guide (PDF file - CD-ROM1)**

Describes procedures for configuring the machine and computers in a network environment.

❖ **Copy Reference**

Describes operations, functions, and troubleshooting for the machine's copier function.

❖ **Printer Reference 1**

Describes system settings and operations for the machine's printer function.

❖ **Printer Reference 2 (PDF file - CD-ROM1)**

Describes operations, functions, and troubleshooting for the machine's printer function.

❖ **Scanner Reference (this manual) (PDF file - CD-ROM1)**

Describes operations, functions, and troubleshooting for the machine's scanner function.

❖ **Manuals for DeskTopBinder V2 Lite**

DeskTopBinder V2 Lite is a utility included on the CD-ROM labeled "Scanner Driver & Document Management Utilities".

- DeskTopBinder V2 Lite Setup Guide (PDF file - CD-ROM2)
Describes the installation of DeskTopBinder V2 Lite and the operating environment for DeskTopBinder V2 Lite in detail. This guide can be displayed from the **[Setup]** dialog box when DeskTopBinder V2 Lite is installed.
- DeskTopBinder V2 Lite Introduction Guide (PDF file - CD-ROM2)
Describes operations with DeskTopBinder V2 Lite and provides an overview of its functions. This guide is added to the **[Start]** menu when DeskTopBinder V2 Lite is installed.

- Auto Document Link Guide (PDF file - CD-ROM2)
Describes operations and functions of Auto Document Link installed with DeskTopBinder V2 Lite. This guide is added to the **[Start]** menu when DeskTopBinder V2 Lite is installed.

❖ **Manuals for ScanRouter V2 Lite**

ScanRouter V2 Lite is a utility included on the CD-ROM labeled "Scanner Driver & Document Management Utilities".

- ScanRouter V2 Lite Setup Guide (PDF file - CD-ROM2)
Describes the installation of ScanRouter V2 Lite settings, and the operating environment for ScanRouter V2 Lite in detail. This guide can be displayed from the **[Setup]** dialog box when ScanRouter V2 Lite is installed.
- ScanRouter V2 Lite Management Guide (PDF file - CD-ROM2)
Describes delivery server management and operations, and provides an overview of ScanRouter V2 Lite functions. This guide is added to the **[Start]** menu when ScanRouter V2 Lite is installed.

❖ **Other manuals**

- PS3 Supplement (PDF file - CD-ROM1)
- Unix Supplement (Available from an authorized dealer or as a PDF file on our Web site)

TABLE OF CONTENTS

Manuals for This Machine	i
How to Read This Manual	1
Symbols	1
Names of Major Options	2

1. Network Scanner

Outline	3
E-mail	3
Network Delivery Scanner.....	4
Document Server	5
Network TWAIN Scanner	6
Control Panel	7
Display Contents	8

2. Preparations for Use as a Network Scanner

Initial Scanner Setup	11
Default Settings	11
Basic Settings	13
Scanner Settings.....	17
Subject Settings	21
Installing Software	23
Auto Run Program	23
Software for Using a Network TWAIN Scanner	25
Software for Using the Network Delivery Scanner Function	26
DeskTopBinder V2 Lite	27
Software Supplied on CD-ROM	28

3. Setting Originals

Placing Originals	33
Placing on the Exposure Glass	34
Placing in the Auto Document Feeder	35
Original Orientation and Scan Area	37
For a Network Delivery Scanner and E-mail	37
For a Network TWAIN Scanner.....	39
Scanning Originals in Several Times	40

4. Sending Stored Scan Data by E-mail

Preparation for Sending by E-mail	43
Screen Configuration	44
Procedure for Sending E-mail	45
Simultaneous Storage and Sending of E-mail	53
Checking the Status of E-mail	55

5. Using the Network Delivery Scanner Function

Preparation for Delivering	57
Screen Configuration	58
Delivering Stored Scan Data	60
Delivery Procedure.....	60
Simultaneous Delivery and Storage.....	67
Checking the Status of Delivery	69

6. Using the Document Server Function

Storing Data	71
Storage Procedure	72
Viewing a List of Stored Files	76
Viewing the List	77
Searching for Files	80
Sending or Delivering Stored Files.....	81
Managing Stored Files	83
Deleting Files	83
Changing File Information.....	84

7. Using the Network TWAIN Scanner Function

Preparation for Using the Network TWAIN Scanner	87
Scanning Originals	88
Functions of the TWAIN Driver	90

8. Appendix

Relationship between Resolution and Data Size	91
When Using for E-mail, or as a Network Delivery Scanner, or Document Server ...	91
When Using as a Network TWAIN Scanner.....	92
Relationship between File Type Specified and File Type Used When Sending E-mail ...	94
Troubleshooting	95
When Scanning Is Not Performed as Expected.....	95
When the Delivery Function Does Not Work.....	95
When an Error Message Appears on the Control Panel	96
When an Error Message Appears on the Client Computer.....	102
Specifications	105
INDEX	106

How to Read This Manual

Symbols

In this manual, the following symbols are used:

 **Important**

If this instruction is not followed, paper might be misfed, originals might be damaged, or data might be lost. Be sure to read this.

 **Preparation**

This symbol indicates the prior knowledge or preparations required before operating.

 **Note**

This symbol indicates precautions for operation or actions to take after misoperation.

 **Limitation**

This symbol indicates numerical limits, functions that cannot be used together, or conditions in which a particular function cannot be used.

 **Reference**

This symbol indicates a reference.

[]

Keys that appear on the machine's panel display.

[]

Keys and buttons that appear on the computer's display.

[]

Keys built into the operation panel of the machine.

[]

Keys on the computer's keyboard.

Names of Major Options

Major options of this machine are referred to as follows in this manual:

- Printer/Scanner Unit Type 2105 → printer/scanner controller

The following software products are referred to using a general name:

- DeskTopBinder V2 Lite and DeskTopBinder V2 Professional → DeskTop-Binder V2 Lite/Professional
- ScanRouter V2 Lite and ScanRouter V2 Professional (optional) → ScanRouter V2 Lite/Professional

1. Network Scanner

Outline

By installing the printer/scanner controller, the machine can be used as a network scanner.

As a network scanner, the machine can send e-mail, operate as a network delivery scanner, store scan data in the Document Server, and operate as a network TWAIN scanner.

E-mail

A scanned image that is attached to an e-mail can be delivered using the e-mail system through a LAN or the Internet.

Reference

p.43 "Sending Stored Scan Data by E-mail"

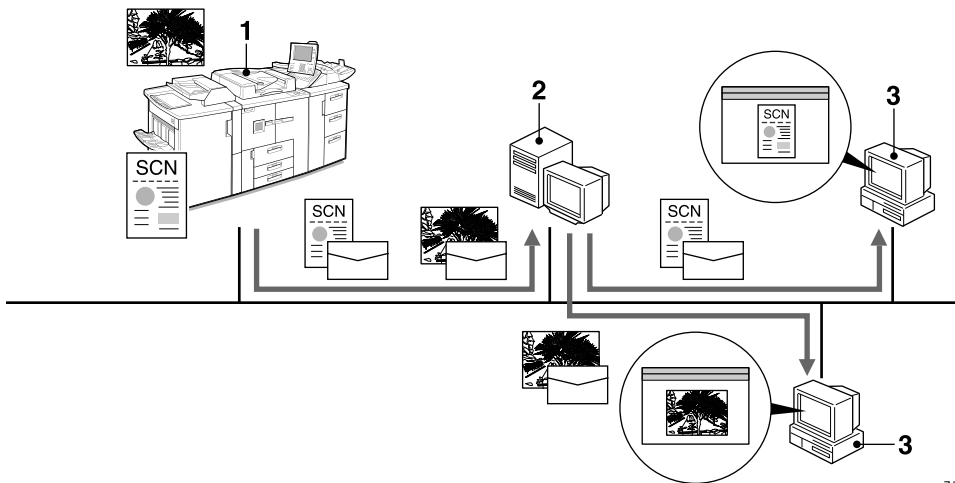

ZJDA121E

1. This machine

A scanned image that is attached to an e-mail can be delivered to an e-mail server. In combination with the document storage function, scanned images and documents that have been temporarily stored can be delivered all at once.

2. E-mail server

An e-mail server is the SMTP server used for an e-mail system. It transfers a received e-mail to a specified destination through a LAN or the Internet.

3. Client computer

An e-mail with images attached is received from the e-mail server using e-mail software. Check the content of the images using an application appropriate for the file type.

Network Delivery Scanner

The machine is used as a delivery scanner with ScanRouter V2 Lite/Professional. The data from the originals scanned by the machine is stored in the delivery server and delivered to the folders of client computers on the same network.

Reference

p.57 "Using the Network Delivery Scanner Function"

Note

- When the optional ScanRouter V2 Professional is used, the machine can also deliver scan data using e-mail, and documents can be viewed from a client computer using a Web browser.

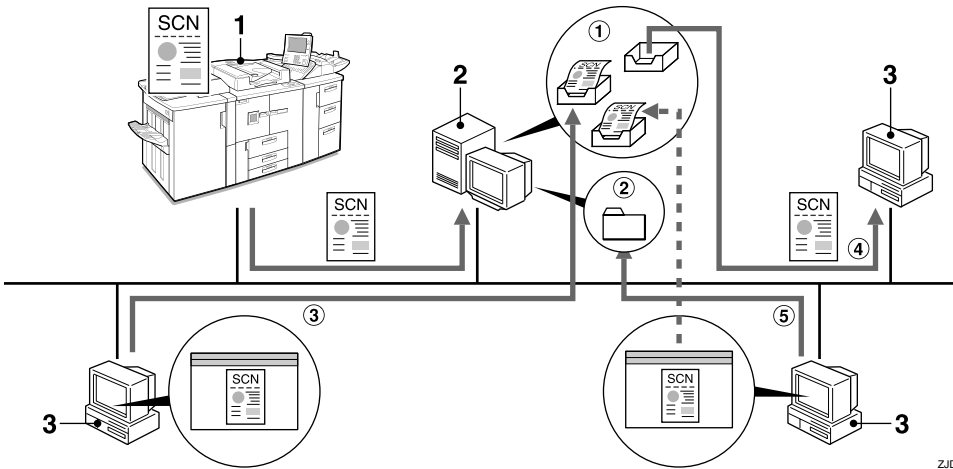

ZJDH010E

1. This machine

The data from the originals scanned by the scanner is sent to the delivery server. When used with the Document Server, multiple documents can be stored and then delivered.

2. Delivery server

ScanRouter V2 Lite/Professional is installed in this computer which is used as a delivery server.

Received data is delivered to the in-tray of the specified destination (1 in the figure). According to the settings of the in-tray, the data is stored in the in-tray or in a Windows folder (2 in the figure).

3. Client computer

The contents of a stored document can be checked in the following ways:

- View the document in the in-tray using DesktopBinder V2 Lite to check the contents. (3 in the figure)
- Use Auto Document Link to receive the document stored in the in-tray, and check the contents with an application corresponding to the file format. (4 in the figure)
- Access the Windows folder where the document is stored via the network, and check the contents with an application corresponding to the file format. (5 in the figure)

Reference

For more information about ScanRouter V2 Lite, DeskTopBinder V2 Lite, or Auto Document Link, see the respective documentation. See p.i “Manuals for This Machine”.

1

Document Server

The data from a scanned original is stored as a document on the hard disk of the machine and can be viewed, copied, or deleted using DeskTopBinder V2 Lite/Professional from a client computer via a network. A document can be searched for using the user name or the document name. Also, others can be kept from viewing a document by setting a password for the document.

Reference

p.71 “Using the Document Server Function”

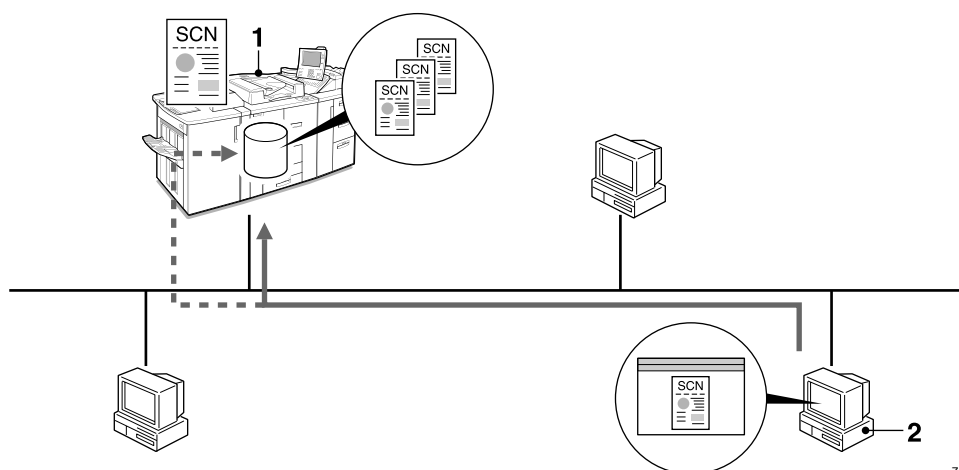

ZJDX030E

1. This machine

The data from the originals scanned by the scanner are stored.

2. Client computer

A stored document can be viewed, copied, or deleted by connecting to the machine using DeskTopBinder V2 Lite/Professional.

Also, a document stored in the machine using a Web browser can be viewed, downloaded, or deleted.

Reference

For more information about DeskTopBinder V2 Lite, see the DeskTopBinder V2 Lite manuals. See p.i “Manuals for This Machine”.

Network TWAIN Scanner

The scanning function of this machine can be used from a client computer via a network (Ethernet, IEEE 1394 [optional], or a wireless LAN). Originals can be scanned with the same operation used for SCSI- and USB-connected scanners.

Reference

p.87 "Using the Network TWAIN Scanner Function"

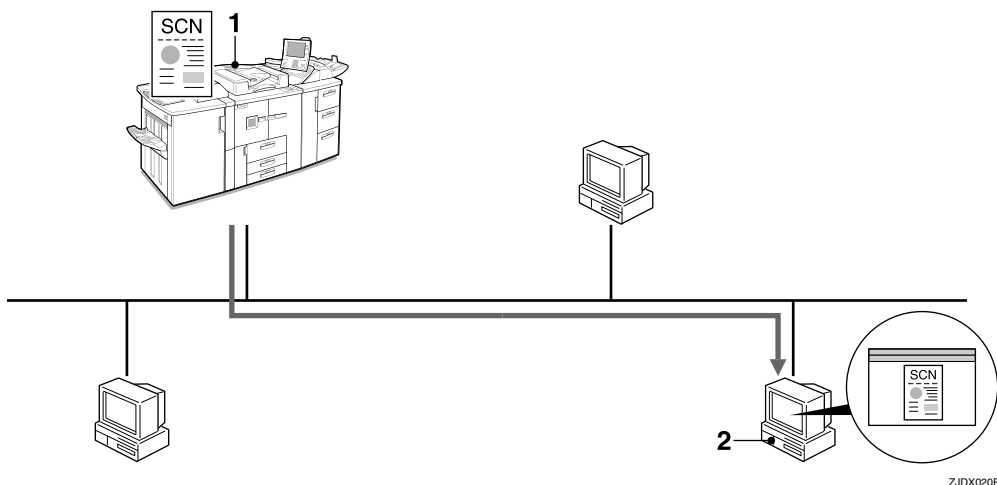

ZJDX020E

1. This machine

The scanning function of the machine can be used from a client computer via a network.

2. Client computer

Originals are scanned using the TWAIN driver for the machine from an application.

Control Panel

This illustration shows the control panel when options are installed.

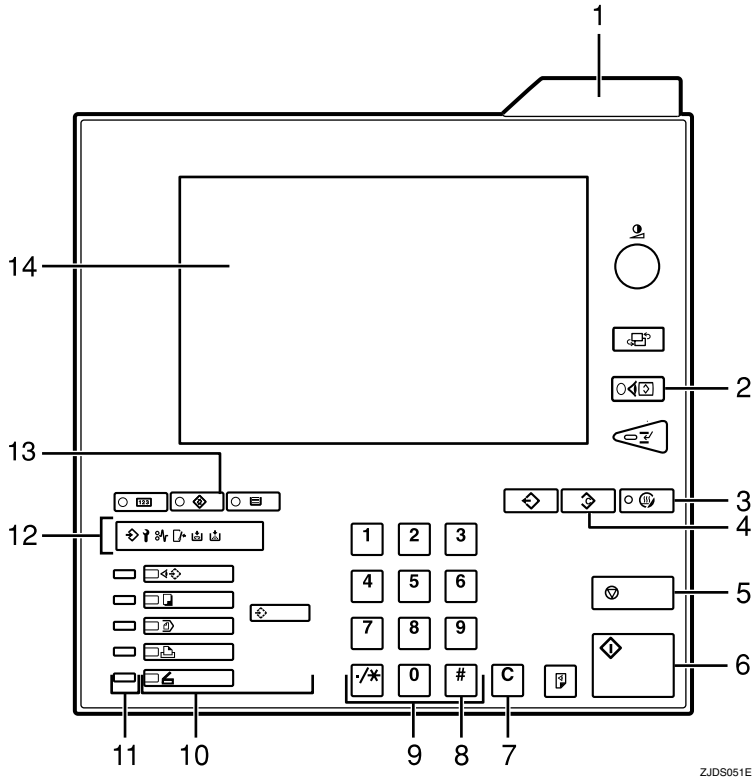

1. **【Status indicator】**

Machine status is described by this indicator. By default, this indicator is turned off. You can select to light the status indicator. For more information, see “Control Panel”, *General Settings Guide*.

2. **【Check Modes】 key**

Press to check the current settings.

3. **【Energy Saver】 key**

Press this key for about one second to begin warm-up.

Pressing this key again while in warm-up mode cancels warm-up.

Note

- This key is inactive while scanning or setting scanner defaults.

4. **【Clear Modes】 key**

Press to clear the current settings.

5. **【Stop】 key**

Press to stop scanning.

6. **【Start】 key**

Use to begin scanning, file storing, or delivery.

7. **【Clear】 key**

Clears an entered numeric value.

8. **【#】 key (Enter key)**

Use to enter a numeric value.

9. **Number keys**

Use to enter numeric values.

10. Function keys

Press the **[Copy]**, **[Document Server]**, **[Printer]**, or **[Scanner]** key to activate the respective function. The display content changes accordingly.

The indicator for the selected function lights up.

11. Function status indicators

These show the status of the function.

- Green: the function is active.
- Red: the function has been interrupted.

12. Indicators

Display errors and the machine status.

!: Service Call indicator

⚠: Misfeed indicator

🔒: Open Cover indicator

📄: Add Staple indicator

🖨: Add Toner indicator

🔍 Reference

For more information, see *General Settings Guide*.

13. **[User Tools]** key

Use to change default or operation parameters according to the operating conditions.

14. Display panel

Displays the operation status and messages.

Display Contents

This section describes the normal screen configuration is as follows.

The display's contents differ depending on the function.

📌 Note

- The Copy screen is set as the default screen when the machine is turned on. You can change this setting in the System Settings. See *General Settings Guide*.

Using as a network TWAIN scanner

When using the machine as a network TWAIN scanner, it is not necessary to press the **[Scanner]** key on the control panel. When the TWAIN driver becomes active on a client computer, the display automatically switches to the following screen.

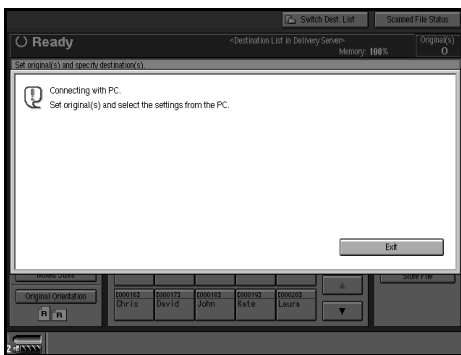

Press **[Cancel]** to use functions other than the network TWAIN scanner function.

Using as a network delivery scanner

Press the **[Scanner]** key to display the Network Delivery Scanner screen (when **[Delivery Server]** has been selected in **[Destination List Priority]**). If the Network TWAIN Scanner screen appears, press **[Cancel]**.

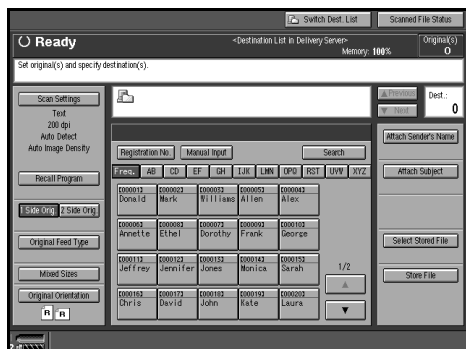

Reference

For information about Destination List Priority, see p.17 “Scanner Settings”.

Using e-mail

Press the **[Scanner]** key to display the E-mail screen (when **[E-mail]** has been selected in **[Destination List Priority]**). If the Network TWAIN Scanner screen appears, press **[Cancel]**.

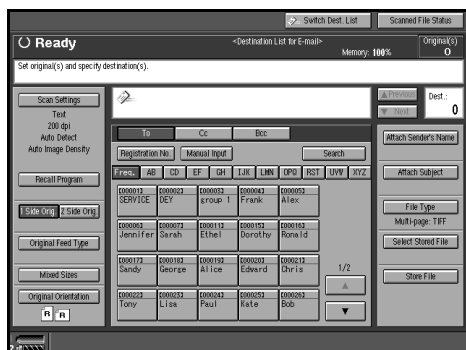

Reference

For information about Destination List Priority, see p.17 “Scanner Settings”.

2. Preparations for Use as a Network Scanner

To use the machine as a network scanner, you must make settings required for use as a scanner as well as basic settings for use in a network.

Reference

First, see *General Settings Guide* for details about how to make basic settings, and then make scanner settings.

For more information about settings for sending by e-mail, see *Network Guide*.

Initial Scanner Setup

This section explains all required settings and procedures for using the machine as a network scanner.

Default Settings

The settings for using the network scanner functions of the machine are listed below. Make the necessary settings.

Important

Items marked ○ should be set if required.

❖ Scanner Features

For explanations of settings, see the corresponding pages.

Settings		Default	TWAIN *1	Delivery *2	E-mail *3	Store *4
Basic Settings See p.13 "Basic Settings".	Scan Type	Text		○	○	○
	Resolution	200 dpi		○	○	○
	Image Density	Auto Image Density (Medium)		○	○	○
	Scan Size	Auto Detect		○	○	○

Settings		Default	TWAIN * ¹	Delivery * ²	E-mail * ³	Store * ⁴
Scanner Settings See p.17 "Scanner Settings".	Send/Store Connection Timeout	10 seconds	<input type="radio"/>	<input type="radio"/>	<input type="radio"/>	<input type="radio"/>
	Compression (Black & White)	On		<input type="radio"/>	<input type="radio"/>	<input type="radio"/>
	Compression (Gray Scale)	Standard		<input type="radio"/>	<input type="radio"/>	<input type="radio"/>
	Destination List Priority	Delivery Server		<input type="radio"/>	<input type="radio"/>	
	Select Title	Title 1		<input type="radio"/>	<input type="radio"/>	
	Sender's Name Default	No			<input type="radio"/>	
	Max. E-mail Size	2048KB			<input type="radio"/>	
	Divide & Send E-mail	Yes (per Max. Size)			<input type="radio"/>	
	E-mail Information Language	British English			<input type="radio"/>	
	File Type Priority	Multi-page: TIFF			<input type="radio"/>	
	Job Reset Time in Adding Original	Off		<input type="radio"/>	<input type="radio"/>	<input type="radio"/>
	Original Setting	1 Sided Original		<input type="radio"/>	<input type="radio"/>	<input type="radio"/>
	Original Feed Type Priority	Off		<input type="radio"/>	<input type="radio"/>	<input type="radio"/>
	Mixed Original Sizes Priority	Off		<input type="radio"/>	<input type="radio"/>	<input type="radio"/>
	Original Orientation Priority			<input type="radio"/>	<input type="radio"/>	<input type="radio"/>
Print & Delete Scanner Journal	Delete All after Printing		<input type="radio"/>	<input type="radio"/>		
Update Delivery Server Destination List	--		<input type="radio"/>			
Subject Settings See p.21 "Subject Settings".	Not programed		<input type="radio"/>	<input type="radio"/>		

*¹ Settings for the network TWAIN scanner function

*² Settings for the network delivery scanner function

*³ Settings for the e-mail function

*⁴ Settings for the Document Server function

Basic Settings

Various basic settings (scan type, resolution, image density, scan size) can be set. When using the same type of original repeatedly, storing the optimum settings in advance makes them easy to select whenever you deliver scan data, send scan data by e-mail, or store scan data.

Note

- ❑ Twenty-five sets of settings named “Initial Setup” and “Program 1” to “Program 24” can be stored for quick recall. The settings stored as Initial Setup are the scanning defaults. If the settings are not selected before scanning or sending by e-mail, the originals are scanned with the settings stored in the Initial Setup.
- ❑ “Program 1” to “Program 24” can be changed to names of up to 20 characters.

The Basic Settings consist of the following items:

❖ Scan Type

Select the scan type suitable for the original from the following:

- Text
For standard originals containing mainly text (Print)
- Text/Photo
For originals containing a mixture of text and photographs
- Photo
For originals containing photographs and other pictures (two-value)
- Gray Scale
For originals containing photographs and other pictures (multi-value)

Note

- ❑ An image is scanned in black & white with Photo, and in gray-scale with Gray Scale. As a general rule, scanning for the purpose of printing is best done with Photo and scanning for viewing on the computer screen with Gray Scale.

❖ Resolution

Select the resolution from 100 dpi, 150 dpi, 200 dpi, 300 dpi, 400 dpi, or 600 dpi.

❖ Image Density

Select the image density from seven steps by pressing **[Lighter]** or **[Darker]** or use Auto Image Density.

❖ Scan Size

Select the size of the original to be scanned.

- When **[Auto Detect]** is selected, the auto detect function of the machine is used to set the original size.
- When the size is specified, scanning is performed for that size, regardless of the actual size of the original. The following sizes can be selected:
A3, A4, A4, A5, A5, 11 x 17, 8¹/₂ x 14, 8¹/₂ x 13, 8¹/₂ x 11, 8¹/₂ x 11, 5¹/₂ x 8¹/₂, 5¹/₂ x 8¹/₂, B4 JIS (Japanese Industrial Standard), B5 JIS, B5 JIS, Custom Size

Note

- ❑ When **[Custom Size]** is selected, the dimensions of the scan area (width and height) can be specified.

- When scanning from the ADF by specifying the original size, if the scanned original size differ from the size specified, a paper jam may occur.

2

Setting procedure

1 Press the **[User Tools]** key.

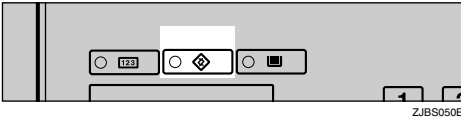

2 Press **[Scanner Features]**.

3 Make sure that the **[Basic Settings]** tab is displayed.

4 Check that **[Program/Change]** is selected, and then select the name of the basic settings set you want to program.

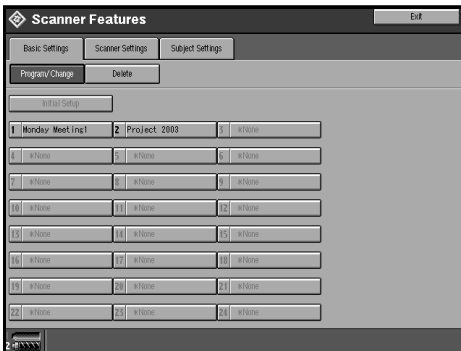

The soft keyboard is displayed for entering a name for the set of settings.

5 Enter the name, and then press **[OK]**.

Reference

For information about entering characters, see *General Settings Guide*.

The screen for the basic settings appears.

6 Select a value for each item (scan type, resolution, image density, scan size).

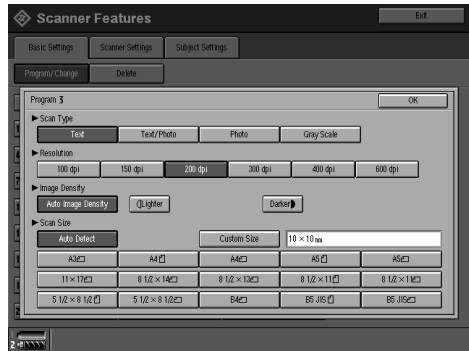

Note

- When selecting **[Custom Size]** for the scan size, see p.15 “Selecting a custom size”.

7 When all settings have been made, press **[OK]**.

8 To program another basic settings set, repeat the procedure from step 4.

9 When all settings have been made, press **[Exit]**.

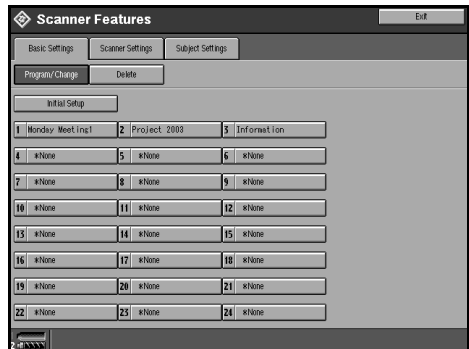

10 Press **[Exit]**.

The main menu reappears.

Selecting a custom size

When selecting **[Custom Size]** as the scan size, follow the procedure below.

- 1 Press **[Custom Size]** for the scan size on the **[Basic Settings]** tab.

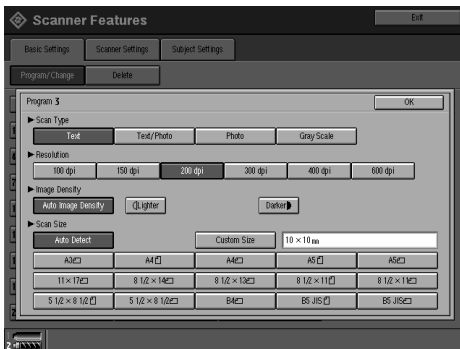

- 2 Enter the original size with the number keys.

Select and enter values for **[X1]** and **[Y1]**.

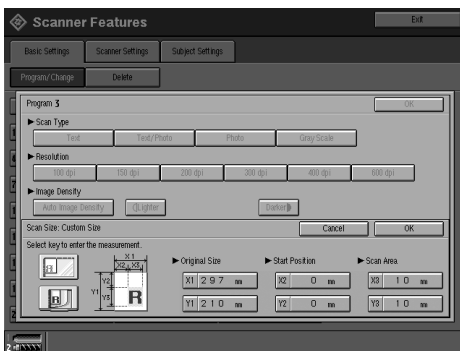

- 3 Enter the scan starting point in relation to the standard scan starting point.

Select and enter values for **[X2]** and **[Y2]**.

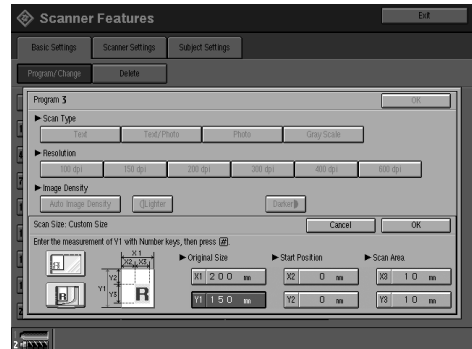

- 4 Enter the scan size (area) with the number keys.

Select and enter values for **[X3]** and **[Y3]**.

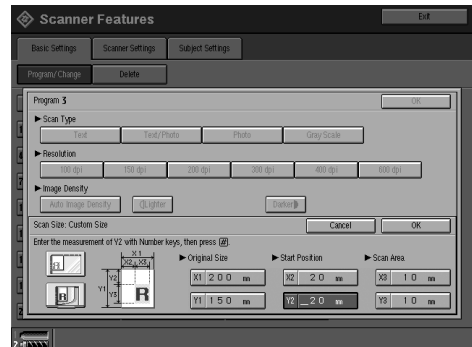

2

Depending on how the original is positioned, the scan area will be as shown.

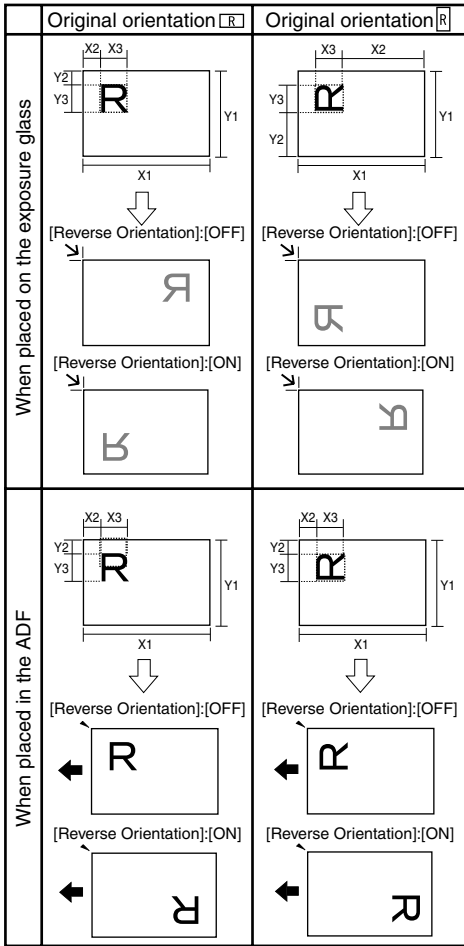

The range of possible original sizes and scan sizes is as follows:

- Original Size
 - X1: 10 mm - 432 mm (0.4" - 17.0")
 - Y1: 10 mm - 297 mm (0.4" - 11.7")
- Scan Size
 - X3: 10 mm - 432 mm (0.4" - 17.0")
 - Y3: 10 mm - 297 mm (0.4" - 11.7")

Keep the scan area settings within these range.

5 When all dimensions are entered, press [OK].

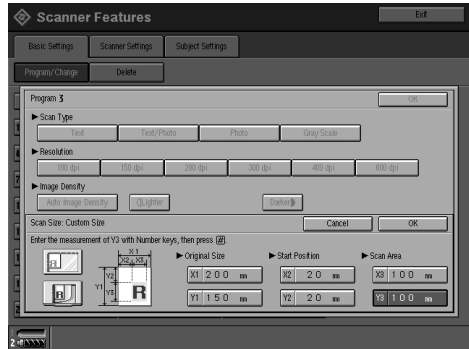

6 Make sure that the area specified in step 4 (X3 and Y3) is shown in the [Custom Size] field, and then press [OK].

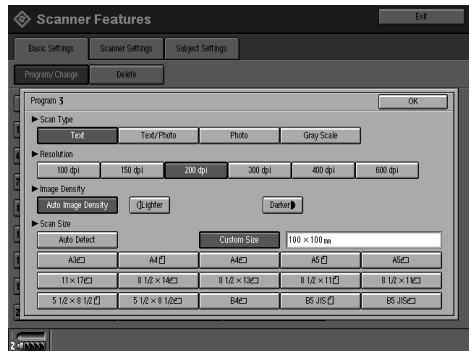

7 Press [Exit].

8 Press [Exit].

The main menu reappears.

Deleting programmed scan settings

1 Press the [User Tools] key.

2 Press [Scanner Features].

3 Make sure that the [Basic Settings] tab is displayed.

4 Press [Delete].

- 5** Select the set of settings you want to delete.

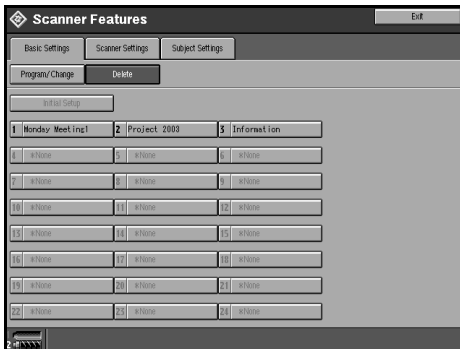

A confirmation message appears.

- 6** Press **[Yes]**.

- 7** Press **[Exit]**.

- 8** Press **[Exit]**.

The main menu reappears.

Scanner Settings

This section explains how to set the defaults for scan settings such as the compression level for scan data and how the machine switches between the e-mail, network delivery scanner, Document Server and network TWAIN scanner functions.

The scanner settings consist of the following. For the list about settings and defaults, see p.11 “Scanner Features”.

❖ Send/Store Connection Timeout

When the machine is functioning as a network delivery scanner or Document Server, or is being used to send e-mail, a scanning request to the machine as a TWAIN scanner will switch the machine to the network TWAIN scanner function. This setting determines the delay until the machine switches to the network TWAIN scanner function.

- When **[Immediate]** is selected, the machine will switch to the network TWAIN scanner function at once.
- When **[Set Time]** is selected, you can enter the delay time with the number keys (3 to 30 seconds). The machine will switch to the network TWAIN scanner function when the time set here passes after the last key operation.

❖ Compression (Black & White)

This setting determines whether image data scanned with the black & white setting is to be compressed.

Note

- The actual time required for data transfer will vary depending on the data size and network load.
- Compression reduces the time required for transferring the scan data to the delivery server or e-mail server.

❖ Compression (Gray Scale)

This setting determines to what extent image data scanned with the grayscale setting is to be compressed. You can select **[Standard]**, **[High]**, **[Low]**, or **[Off]**.

Note

- The compression ratio decreases in the order **[High]**, **[Standard]**, **[Low]**, and **[Off]**, and the time required for data transfer increases accordingly.
- The actual time required for data transfer will vary depending on the data size and network load.

❖ Destination List Priority

Select a destination list to be displayed when the machine is in the initial state. Select either **[Delivery Server]** or **[E-mail]**.

❖ Select Title

Select what titles are displayed on the screen. Selecting a title on the screen will display the destinations programmed for that title. This allows for easy selection of destinations including e-mail destinations. Select either **[Title 1]** (ten titles), **[Title 2]** (ten titles), or **[Title 3]** (five titles).

❖ Sender's Name Default

Select whether an administrator is registered as a sender or a sender is specified each time an e-mail is sent.

- Select **[No]** when a sender is to be specified each time.
- Select **[Yes]** when an administrator is to be the sender.

🔔 Important

- It is recommended that a password be set to prevent the sender's name from being misused.

❖ Max. E-mail Size

Select whether the size of an e-mail is limited or not.

When **[On]** is selected, enter the size limit (64 - 102400 KB) using the number keys.

📝 Note

- When the SMTP limits the size, match that setting.

❖ Divide & Send E-mail

This function is effective only when **[On]** is selected for **[Max. E-mail Size]**.

Select whether or not an image exceeding the size specified in **[Max. E-mail Size]** should be divided and sent using more than one e-mail.

Select either **[No]**, **[Yes (per Page)]**, or **[Yes (per Max. Size)]**.

📝 Note

- When **[Multi-page: TIFF]** or **[Multi-page: PDF]** is selected for **[File Type Priority]**, the image will not be divided even if **[Yes (per Page)]** is selected.
- When **[Yes (per Max. Size)]** is selected, some received files may not be able to be restored, depending on the type of e-mail software.
- When **[No]** is selected, the e-mail is not sent if its size exceeds the limit, and an error message appears. The scanned data is discarded.
- Set the maximum e-mail size within the capacity of the SMTP server.

❖ E-mail Information Language

Select a language for E-mail Information Language with which Title, Document name, Sender's name and others are sent.

Select one of the following 18 languages: British English, American English, German, French, Italian, Spanish, Dutch, Portuguese, Polish, Czech, Swedish, Finnish, Hungarian, Norwegian, Danish, Japanese, Simplified Chinese, and Traditional Chinese.

📝 Note

- The e-mail text is a template and cannot be changed.

❖ File Type Priority

Select whether to send the data of scanned originals using a single page, a multi-page TIFF, or a multi-page PDF.

Note

- If you specify a multi-page TIFF format for data in a JPEG format, the format is automatically changed to a PDF format. See p.91 “Relationship between Resolution and Data Size”.

❖ Job Reset Time in Adding Original

When SADF mode is specified, select whether or not the machine waits for another original to be set after all originals in the Auto Document Feeder (ADF) or on the exposure glass have been scanned.

Note

- If neither the SADF mode or Batch mode is specified when scanning, this setting becomes invalid and the machine ends the scanning operation without waiting for more originals.
- If **[Off]** is selected, the count-down does not occur and the machine enters the waiting state when all originals in the ADF have been scanned in SADF mode or Batch mode until another original is inserted or the **[#]** key is pressed.

- If **[On]** is selected, enter the number of seconds (3 - 900) for the Job Reset Time in Adding Original with the number keys. When an original is placed within this time, it is scanned as part of the same document as the previously scanned originals. However, when Batch mode is specified, the machine stays in the waiting state regardless of the setting time until another original is inserted or the **[#]** key is pressed.

❖ Original Setting

Set the default for whether originals are one-sided or two-sided and if two-sided, the relationship between those sides. When the originals are always the same, set this for the default to make operation easier. You can select **[1 Sided Original]**, **[2 Sided Original: Top to Top]**, or **[2 Sided Original: Top to Bottom]**.

Reference

p.37 “Original Orientation and Scan Area”

❖ Original Feed Type Priority

When placing additional originals in the ADF, select whether to add sheets individually or to add batches. If **[Off]** is selected, the scanning operation ends after the initially placed originals are scanned without the machine waiting for additional originals to be placed in the ADF.

Note

- ❑ Even if **[On]** is selected for **[Job Reset Time in Adding Original]**, the countdown to scan another original stops when scanning conditions are changed, the exposure glass is used to scan, or the mode of the machine is switched to another mode such as copier mode. Press the **[Start]** key to restart scanning.

❖ **Mixed Original Sizes Priority**

This setting determines whether the original size is to be automatically detected when originals of different sizes are inserted in the ADF. You can select **[On]** or **[Off]**.

Note

- ❑ If the original size is specified when scanning, this setting is ignored.
- ❑ When **[Off]** is selected and originals of different sizes are placed in the ADF, the size of the first page is detected as the max. size and all originals are scanned as that size.

❖ **Original Orientation Priority**

Select the default for original placement orientation. When originals are always positioned the same way, select that orientation as the default to make operation easier.

Reference

p.37 "Original Orientation and Scan Area"

❖ **Print & Delete Scanner Journal**

Select whether to print the Scanner Journal automatically when the number of delivered e-mails reaches 50.

Note

- ❑ When printed, all records are deleted after printing. When not printed, records over the limit are automatically deleted in succession from the oldest record.
- ❑ While the journal is being printed, sending e-mail is on standby.

❖ **Update Delivery Server Destination List**

To update the Delivery Server Destination List, press **[Update Delivery Server Destination List]**.

Ordinarily, the Delivery Server Destination List is automatically updated. This function allows updating at any time.

Setting procedure

- 1 Press the **[User Tools]** key.
- 2 Press **[Scanner Features]**.
- 3 Press the **[Scanner Settings]** tab.
- 4 Press the item to be set.

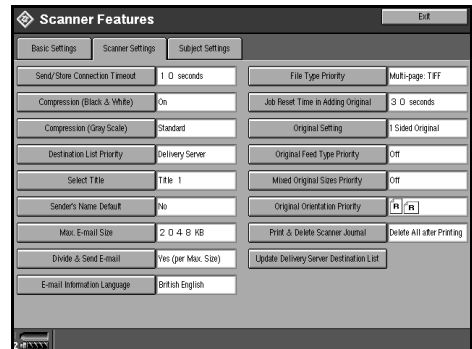

Example: Send/Store Connection Timeout setting

5 Change the setting.

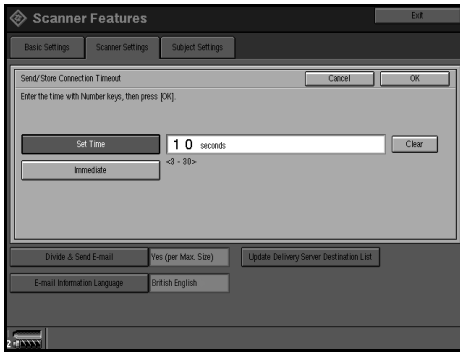

- To select an item, touch its key on the screen. The item is highlighted.
- To enter numbers, use the number keys.

Note

- To cancel changing a setting, press **[Cancel]**. The setting returns to the previous condition.

6 Press **[OK]**.

7 Repeat steps **4** to **6** to make other settings.

8 Press **[Exit]**.

9 Press **[Exit]**.

The main menu reappears.

Subject Settings

Subject information can be added to the scan data files. This information is added to the data to be delivered. When the file is sent by e-mail with the optional ScanRouter V2 Professional, the subject is automatically entered as the subject of the e-mail. If you often send files with similar content, storing subject names will allow you to easily select a subject for delivery.

The subject can be up to 20 characters long. Up to 21 subjects can be stored.

Setting procedure

This section describes the steps for making subject settings.

1 Press the **[User Tools]** key.

2 Press **[Scanner Features]**.

3 Press the **[Subject Settings]** tab.

4 Check that **[Program/Change]** is selected, and then select the key you want to program.

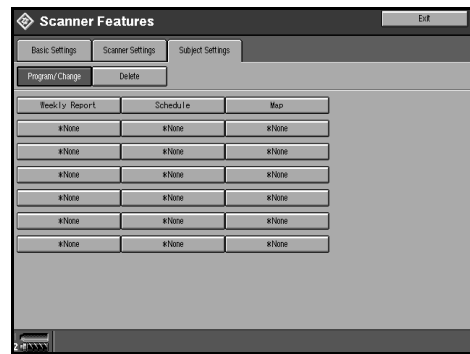

The soft keyboard is displayed for entering a subject.

5 Enter the subject string.

Reference

For information about how to enter characters, see *General Settings Guide*.

Note

- If the selected key already has a programmed subject, it can be changed.

6 Press **[OK]**.

7 To program more subjects, repeat steps **4** to **6**.

8 Press **[Exit]**.

9 Press **[Exit]**.

The main menu reappears.

Deleting programmed subject settings

- 1** Press the **[User Tools]** key.
- 2** Press **[Scanner Features]**.
- 3** Press the **[Subject Settings]** tab.
- 4** Press **[Delete]**.

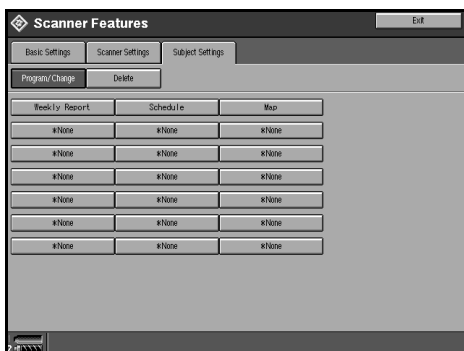

- 5** Select the subject you want to delete.

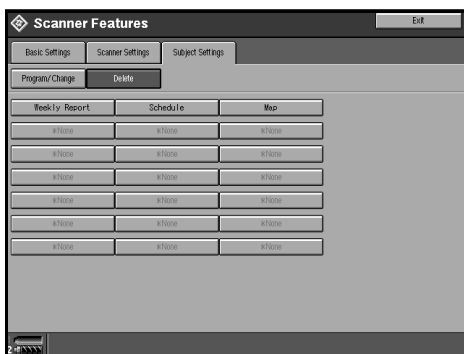

A confirmation message appears.

- 6** Press **[Yes]**.
- 7** To delete more subjects, repeat steps **5** to **6**.
- 8** Press **[Exit]**.
- 9** Press **[Exit]** .

The main menu reappears.

Installing Software

The machine comes with two CD-ROMs containing various software.

The CD-ROM labeled “Scanner Driver & Document Management Utilities” contains the necessary software to use the machine as a network scanner. The CD-ROM labeled “Printer Driver & Utilities” contains the necessary software to use the machine as a printer.

This section explains the software contained on the “Scanner Driver & Document Management Utilities” CD-ROM.

Reference

For information about the software contained on the “Printer Driver & Utilities” CD-ROM, see *Printer Reference*.

Auto Run Program

When the CD-ROM is inserted into a client computer in Windows 95/98/Me, Windows XP, Windows 2000, or Windows NT 4.0, the installer starts automatically (Auto Run) to install the TWAIN driver and various software.

Note

- Auto Run might not automatically work with certain operating system settings. In this case, launch “Set up.exe” located in the CD-ROM root directory.
- If you want to install the software without using Auto Run, hold down the **[Shift]** key while inserting the CD-ROM. Keep the **[Shift]** key held down until the client computer has finished accessing the CD-ROM.
- If **[Cancel]** is pressed during installation, the installation will be stopped and all the remaining software will not be installed. If **[Cancel]** has been pressed, reinstall the remaining software after restarting the computer.

Limitation

- For installation in Windows 2000, Windows XP, or Windows NT 4.0, log on as a member of the administrators group.

The installing sequence using Auto Run is as follows.

Installation Sequence

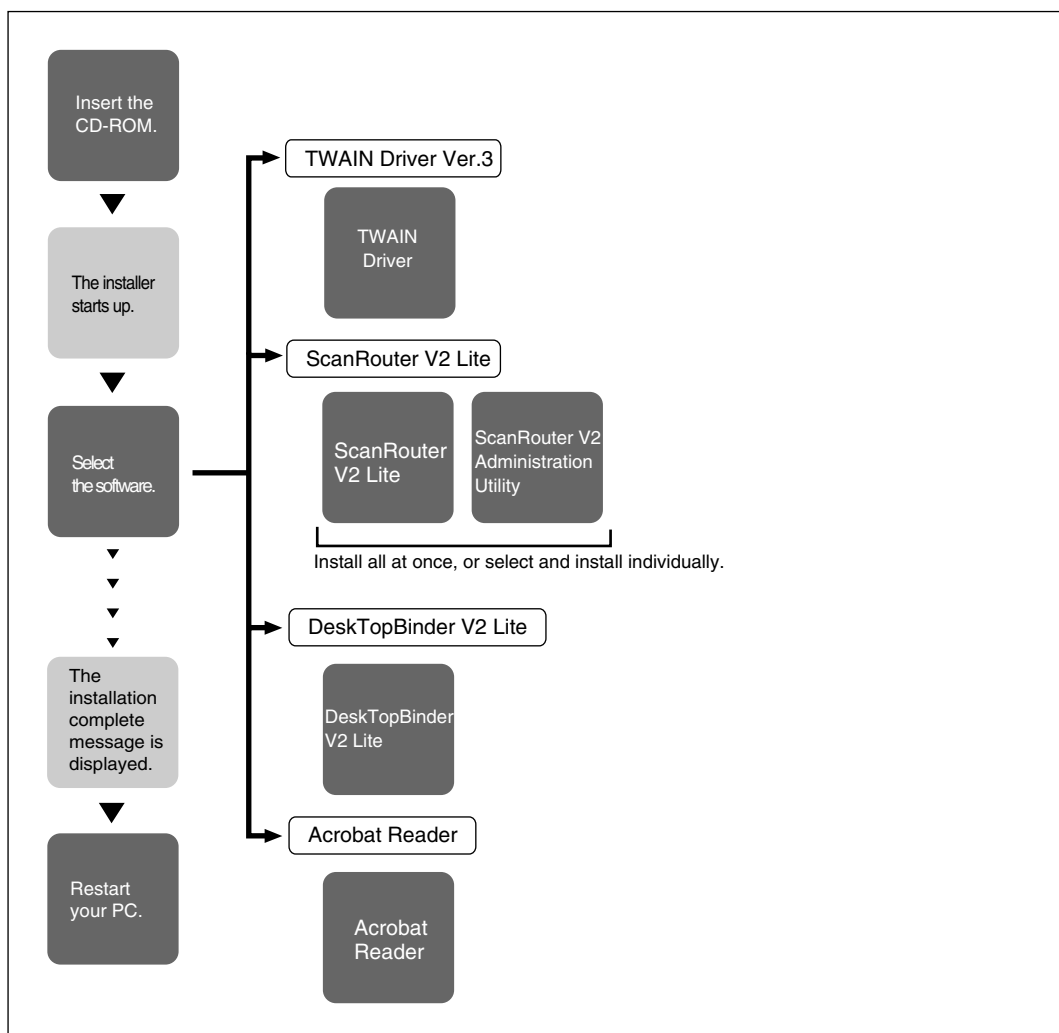

ZHSY070E

For information about the software that can be installed by Auto Run, see p.28 "Software Supplied on CD-ROM".

Software for Using a Network TWAIN Scanner

To use the machine as a network TWAIN scanner, it is essential to install the TWAIN driver.

If you do not have applications that work with TWAIN, it is necessary to also install DeskTopBinder V2 Lite. For information about the installation of DeskTopBinder V2 Lite, see p.27 “DeskTopBinder V2 Lite”.

Preparation

Before installation, check the operating environment for the TWAIN driver. See p.28 “Type2105 TWAIN Driver”.

Using Windows 95/98/Me, Windows XP, Windows 2000, or Windows NT 4.0

Install the TWAIN driver using Auto Run.

1 Start Windows, and then insert the supplied CD-ROM labeled “Scanner Driver & Document Management Utilities” into the CD-ROM drive of the client computer.

The Choose Setup Language screen appears.

Reference

If the installer does not start automatically, see p.23 “Auto Run Program”.

2 Select a setup language, and then click [OK].

The CD-ROM Launcher screen appears.

3 Click [TWAIN Driver].

The Software Setup screen appears.

4 The installer of the TWAIN driver starts. Follow the instructions on the screen.

Note

- When the installation is complete, a message to prompt you to restart the client computer may appear. In this case, restart the client computer.
- After the installation is complete, the “Type2105 TWAIN V3” folder is in the “Program” folder on the Start menu. Help can be displayed from here.
- Notes on using the network TWAIN scanner are provided in “Readme.txt”. Be sure to read them before use.

Software for Using the Network Delivery Scanner Function

To use the machine as a network delivery scanner, it is essential to install ScanRouter V2 Lite on the delivery server. To check an in-tray or retrieve documents, it is necessary to install DeskTopBinder V2 Lite on the client computer.

Use Auto Run for installation.

2

Preparation

Before installation, check the system requirements for the software. See p.28 “Software Supplied on CD-ROM”.

1 Start Windows, and then insert the supplied CD-ROM labeled “Scanner Driver & Document Management Utilities” into the CD-ROM drive of the client computer.

The Choose Setup Language screen appears.

2 Select a setup language, and then click [OK].

The CD-ROM Launcher screen appears.

3 Click the key of the software to be installed.

- The DeskTopBinder V2 Lite installer starts by clicking [DeskTopBinder V2 Lite].
- The ScanRouter V2 Lite installer starts by clicking [ScanRouter V2 Lite].

The Change The Language screen appears.

Reference

For information about the subsequent installation procedure, see *Setup Guide* that can be displayed from the Setup screen of the respective software.

4 Select a language, and then click [OK].

The Software Setup screen appears.

DeskTopBinder V2 Lite

Use Auto Run for installation.

Preparation

Before installation, check the system requirements for DeskTopBinder V2 Lite. See p.29 “DeskTopBinder V2 Lite”.

- 1 Start Windows, and then insert the supplied CD-ROM labeled “Scanner Driver & Document Management Utilities” into the CD-ROM drive of the client computer.**

The Choose Setup Language screen appears.

- 2 Select a language, and then click [OK].**

The CD-ROM Launcher screen appears.

- 3 Click [DeskTopBinder V2 Lite].**

The Change The Language screen appears.

- 4 Click [DeskTopBinder V2].**

Reference

For information about the subsequent installation procedure, see *Setup Guide* that can be displayed from the Setup screen of DeskTopBinder V2 Lite.

- 5 Select a language, and then click [OK].**

The Software Setup screen appears.

Software Supplied on CD-ROM

List of files

CD-ROM Drive	Wizard for the TWAIN driver and utilities		
	Drivers	Twain	TWAIN driver for Windows 95/98/Me, Windows XP, Windows 2000, Windows NT 4.0
	Utility	RouterV2	ScanRouter V2 Lite , ScanRouter V2 Administration Utility
		DeskV2	DeskTopBinder V2 Lite
Acroread		Acrobat Reader	

Type2105 TWAIN Driver

This driver is required to scan an original on the machine.

To use the machine as a network TWAIN scanner, this driver must be installed.

❖ File storage folder

The files are stored in the following folder on the CD-ROM provided with this machine.

`\DRIVERS\TWAIN`

❖ System requirements

- Hardware
PC/AT compatible

! Limitation

- Under Windows NT with RISC-based processors (MIPS R series, Alpha AXP, or PowerPC), this driver is not available.
- CPU
Pentium or faster (Pentium 150 MHz or faster recommended)
- Operating system
Microsoft Windows 95
Microsoft Windows 98
Microsoft Windows Millennium Edition
Microsoft Windows XP Professional
Microsoft Windows XP Home Edition
Microsoft Windows 2000 Server
Microsoft Windows 2000 Professional
Microsoft Windows NT Server 4.0 (Service Pack 5 or later)
Microsoft Windows NT Workstation 4.0 (Service Pack 5 or later)

- Memory
Operating system min. operation memory + 8 MB (64 MB or more recommended)
- Hard disk space
100 MB or more
- Display resolution
800 × 600 pixels, 256 colours or higher
- Network protocol
TCP/IP

DeskTopBinder V2 Lite

DeskTopBinder V2 Lite is to be installed on the client computers for integration and management of various kinds of data such as scanned image data, files created with applications, and existing image files. The software allows you to view documents in in-trays of the delivery server. This software can be used to use the machine as a network TWAIN scanner. Also, the documents stored in the Document Server can be viewed.

Reference

See the manuals for DeskTopBinder V2 Lite or DeskTopBinder V2 Lite Help.

❖ File storage folder

The files are stored in the following folder on the CD-ROM provided with this machine.

`\UTILITY\DESKV2`

❖ System requirements

- Hardware
PC/AT compatible
- CPU
Pentium 133 MHz or faster (Pentium II 266 MHz or faster recommended)
- Operating system
Microsoft Windows 95 (OSR 2 or later)
Microsoft Windows 98
Microsoft Windows Millennium Edition
Microsoft Windows XP Professional
Microsoft Windows XP Home Edition
Microsoft Windows 2000 Server (Service Pack 1 or later)
Microsoft Windows 2000 Professional (Service Pack 1 or later)
Microsoft Windows NT Server 4.0 (Service Pack 5 or later)
Microsoft Windows NT Workstation 4.0 (Service Pack 5 or later)
- Memory
48 MB or more (128 MB or more recommended)
- Hard disk space
50 MB or more (200 MB or more recommended)

- Display resolution
800 × 600 pixels, 64K colours or higher
- Network protocol
TCP/IP

❖ **Software installed with DeskTopBinder V2 Lite**

- Auto Document Link
Auto Document Link on the client computer monitors in-trays of the delivery server. In addition, the documents delivered to in-trays can be retrieved or a notification of document arrival can be received at the client computer with this software.

ScanRouter V2 Lite

ScanRouter V2 Lite is to be installed on the delivery server. The data scanned by the machine can be sorted in the delivery server, stored in specified in-trays, or saved in folders of client computers on the same network.

 **Reference**

See the manuals for ScanRouter V2 Lite or ScanRouter V2 Lite Help.

❖ **File storage folder**

The files are stored in the following folder on the CD-ROM provided with this machine.

`\UTILITY\ROUTERV2`

❖ **System requirements**

The following system requirements must be met to use ScanRouter V2 Lite.

💡 **Limitation**

- When installing the software in Windows NT Server or Windows 2000 Server, a stand-alone server must be used. Do not use the primary domain controller or backup domain controller.
- If you install this software in an operating system, such as Windows NT Workstation and Windows 2000 Professional, in which a client server is not permitted to be used in a network, you may violate the license agreement of Microsoft Corporation.
- Hardware
PC/AT compatible
- CPU
Pentium 200 MHz or faster (Pentium II 350 MHz or faster recommended)

- Operating system
 - Microsoft Windows 95 (OSR 2 or later)
 - Microsoft Windows 98
 - Microsoft Windows Millennium Edition
 - Microsoft Windows XP Professional
 - Microsoft Windows XP Home Edition
 - Microsoft Windows 2000 Server (Service Pack 1 or later)
 - Microsoft Windows 2000 Professional (Service Pack 1 or later)
 - Microsoft Windows NT Server 4.0 (Service Pack 5 or later)
 - Microsoft Windows NT Workstation 4.0 (Service Pack 5 or later)

- Memory
 - 64 MB or more (128 MB or more recommended)
- Hard disk space
 - Minimum free space required for installing: 200 MB

 **Note**

- In addition to the space required for installation, the hard disk should have at least 500 MB of free space for files.
- Network protocol
 - TCP/IP

❖ **Software installed with ScanRouter V2 Lite**

- ScanRouter V2 Administration Utility
 - ScanRouter V2 Administration Utility manages the delivery system run by ScanRouter V2 Lite.
 - You can register destination and sender information for the scanned documents in the delivery server. In addition, you can perform maintenance for free disk space monitoring, error log recording, and other features of the delivery server.

 **Note**

- ScanRouter V2 Administration Utility can be installed not only on the delivery server but also on client computers. To install it, click [**ScanRouter V2 Administration Utility**] on the ScanRouter V2 Lite Setup screen.

3. Setting Originals



This chapter explains the procedure for placing originals on the exposure glass and in the ADF, and setting the original scan area and orientation according to the placement method.

To correctly display the top/bottom orientation of the scanned original on a computer, the placement of the original and the settings made on the control panel and scanner driver must match.



Placing Originals







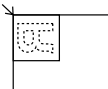
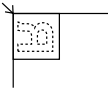
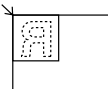
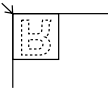
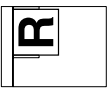
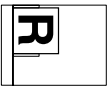

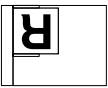



There are four orientations for placing the original. See the table below.

Note

- Normally, an original is  or , but in the table below, a square original is used to make original orientation easy to understand. If the actual shape of the original is different, the combination of original orientation and the orientation specified on the control panel or scanner driver does not change.

◆ Specifying Original Orientation and Setting Originals

<p>1 An original to be scanned</p>				
<p>2 Decide the placement method.</p>	Exposure glass		ADF	
<p>3 Place the original. (There are four original orientations.)</p>	<p>①Place the original so that the top edge touches the top left of the exposure glass.</p>  <p>②Place the original so that the bottom edge touches the top left of the exposure glass.</p> 	<p>③Place the original so that the top edge touches the rear of the exposure glass.</p>  <p>④Place the original so that the bottom edge touches the rear of the exposure glass.</p> 	<p>⑤Place the top edge of the original first.</p>  <p>⑥Place the bottom edge of the original first.</p> 	<p>⑦Place the original so that the top edge touches the back of the ADF.</p>  <p>⑧Place the original so that the bottom edge touches the back of the ADF.</p> 

<p>4 Specify the orientation. (Specified on the control panel screen)</p>	<p>When scanning using the delivery scanner function, Document Server function, or for sending e-mail.</p>	<p>①</p>  <p>Reverse Orientation</p>	<p>③</p>  <p>Reverse Orientation</p>	<p>⑤</p>  <p>Reverse Orientation</p>	<p>⑦</p>  <p>Reverse Orientation</p>
	<p>When scanning using the TWAIN scanner function (Specified in the Scanner Control dialog box)</p>	<p>②</p>  <p>Reverse Orientation</p>	<p>④</p>  <p>Reverse Orientation</p>	<p>⑥</p>  <p>Reverse Orientation</p>	<p>⑧</p>  <p>Reverse Orientation</p>
<p>5 The original displayed on a computer</p>	<p>When scanning using the delivery scanner function, Document Server function, or for sending e-mail.</p>	<p>①</p> 	<p>③</p> 	<p>⑥</p> 	<p>⑦</p> 
	<p>When scanning using the TWAIN scanner function (Specified in the Scanner Control dialog box)</p>				

Placing on the Exposure Glass

Originals which do not fit into the ADF, such as sheets with glued-on parts, books, etc., can be placed directly on the exposure glass for scanning.

Note

- ❑ For information about the originals which can be placed on the exposure glass, see *Copy Reference*.

- 1** Lift the exposure glass cover or the ADF.

Note

- ❑ Lift the exposure glass cover or ADF more than 30 degrees. The opening/closing action triggers the automatic original size detection process.

- 2** Place the original on the exposure glass with the side to be scanned facing down. Align the original with the back left corner mark such as the following illustration.

Reference

p.33 "Placing Originals"

When placing the original so that the top edge touches the rear of the exposure glass.

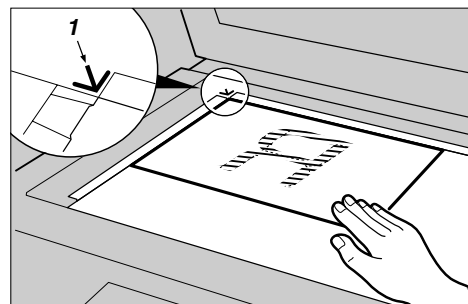

ZJ0Y030E

1. Positioning mark

When placing the original so that the top edge touches the top left of the exposure glass.

When using the machine as a network TWAIN scanner, this orientation is the standard setting for the TWAIN driver. Normally, use this orientation for placing documents.

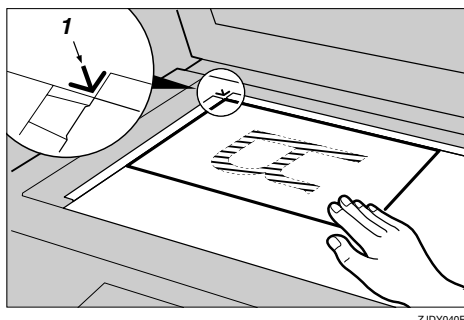

ZJ DY040E

1. Positioning mark

3 Lower the exposure glass cover or the ADF.

4 Select the original orientation according to the orientation of the placed original.

Reference

p.33 "Specifying Original Orientation and Setting Originals"

Proceed to p.37 "Original Orientation and Scan Area".

Placing in the Auto Document Feeder

The ADF allows you to place several originals at one time. Originals placed in the ADF can be scanned on one side or both sides.

❖ Originals that can and cannot be placed in the ADF

For information about the originals that can and cannot be placed in the ADF, see *Copy Reference*.

Attempting to use unsuitable originals in the ADF can lead to a misfeed and damage to the originals. Place such originals directly on the exposure glass.

Important

- For information about which original sizes can be detected automatically and notes on placing originals in the ADF, see *Copy Reference*.
- If you turned on the machine with an original already placed on the exposure glass and started scanning while placing originals in the ADF, a paper jam will occur. Before turning the machine on, check that there is no original on the exposure glass.

1 Adjust the original guide to match the size of the originals.

2 Place the originals with the side to be scanned facing up. (For originals which are to be scanned on both sides, the first side should face up.)

Reference

p.33 "Placing Originals"

When placing the originals so that the top edges touch the back of the ADF.

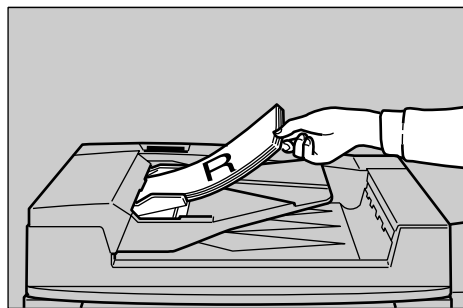

ZJ DY010E

When placing the bottom edges of the originals first.

When using the machine as a network TWAIN scanner, this orientation is the standard setting for the TWAIN driver. Normally, use this orientation for placement.

3

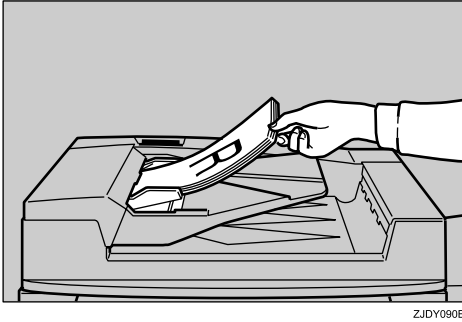

ZJDY090E

Note

- Originals with different sizes can be placed at the same time. Place the originals as shown in the figure below.

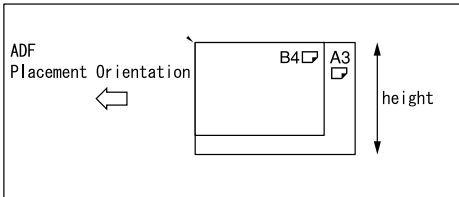

ZHSY080E

- Originals are scanned in the inserted order, starting with the topmost page.

3 Select the original orientation according to the orientation of the placed originals.

Reference

p.33 "Specifying Original Orientation and Setting Originals"

Proceed to p.37 "Original Orientation and Scan Area".

Original Orientation and Scan Area

To correctly display the top/bottom orientation of a scanned original on a computer, original orientation and page flow must be set when placing the original.

When using the network delivery scanner function and e-mail function, settings are made on the control panel of the machine. When using the machine as a network TWAIN scanner, settings are made with the TWAIN driver.

Note

- ❑ The difference between scanning with Auto Detect scan size (non-mixed original sizes), Auto Detect scan size (mixed original sizes), or scan size specification is shown in the following table.

Auto Detect Non-Mixed Original Sizes	A whole batch of originals is scanned using the size of the first original.
Auto Detect Mixed Original Sizes	Auto detection is used to determine the size of each original.
Scan Size Specification	When an original is smaller than the specified scan size, a blank space appears in the resulting image.

For a Network Delivery Scanner and E-mail

- 1 On the network delivery scanner function or e-mail function screen, make settings for one-sided/two-sided combination, original feed type, original orientation, and mixed original sizes.

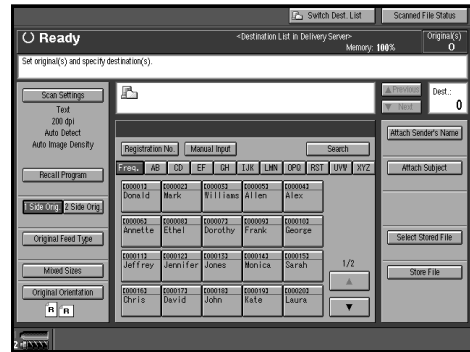

Note

- ❑ The defaults can be changed using the initial scanner settings [Original Setting], [Original Feed Type Priority], [Mixed Original Sizes Priority], and [Original Orientation Priority]. See p.17 "Scanner Settings".

One-sided original/Two-sided original selection

- 1 When scanning one-sided originals, make sure that [2 Side Orig.] is not selected.
- 2 When scanning two-sided originals, press [2 Side Orig.] to select [Top to Top] or [Top to Bottom] according to the binding orientation of the original.

Top to top original:



Top to bottom original:

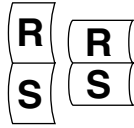

When the last page of two-sided originals is blank, select **[1 Side]** to skip that side and finish scanning, or select **[2 Sides]** to scan that side as a blank page.

Note

- If **[1 Side]** is selected for the last page when scanning originals in several batches, the maximum number of pages per file may decrease depending on the number of batches set.
- If **[1 Side]** is selected for the last page, the image size might become larger than original and may exceed the maximum e-mail size possible. In this case, change the settings of **[Max. E-mail Size]** in scanner settings. See p.11 "Initial Scanner Setup".
- When scanning originals on the exposure glass with the **[2 Side Orig.]** setting, set **[1 Side]** for the last original.

3 Press **[OK]**.

Original feed type selection

- 1** Press **[Original Feed Type]**.
- 2** When scanning a large number of originals using the ADF by dividing the originals and scanning them individually or in batches, check that **[SADF]** or **[Batch]** is selected.

Note

- Select **[SADF]** for adding originals one by one, or select **[Batch]** for adding the originals in batches.
 - Select whether **[SADF]** or **[Batch]** is displayed using the initial scanner setting **[Original Feed Type Priority]**.
- 3** Press **[Mix 1&2 Sided]** to be able to switch between **[1 Side Orig.]** and **[2 Side Orig.]** while scanning originals.

Note

- When either **[SADF]** or **[Batch]** is not selected, **[Mix 1&2 Sided]** cannot be selected.
- When **[Mix 1&2 Sided]** is selected, the scanning mode can be switched by selecting **[1 Side Orig.]** or **[2 Side Orig.]** while the countdown until originals are no longer accepted is progressing. You cannot switch to or from **[1 Side Orig.]** and **[2 Side Orig.]** until the scanning of one original is completed.
- One-sided and two-sided originals are usually output to different trays but when **[Mix 1&2 Sided]** is selected, all originals are output to the same tray reversed (back side facing up) regardless of whether they are one-sided or two-sided originals. Avoid using originals that are unsuitable for the ADF such as thick paper.

4 Press **[OK]**.



Mixed size selection

- 1 When originals of different sizes are placed, make sure that **[Mixed Sizes]** is selected.

Note

- If **[Mixed Sizes]** is not selected, the maximum size detected is set as the scan size. For originals smaller than this size, a blank space will appear in the resulting image.
- If **[Mixed Sizes]** is not selected for originals of different sizes, a paper jam may occur.

Orientation selection

- 1 Press **[Original Orientation]**.
- 2 Press the key for the same orientation as the actual orientation of the original  or .

Reference

p.33 "Specifying Original Orientation and Setting Originals"

- 3 Press **[OK]**.

The current settings are displayed with characters and icons.

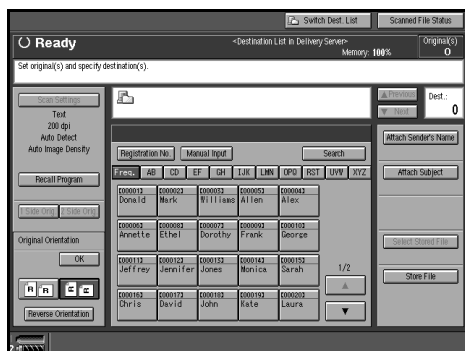

For a Network TWAIN Scanner

- 1 Open the **[Scanner Properties]** dialog box.

Reference

p.88 "Scanning Originals"

- 2 Select the position from the **[Document:]** list in the **[Document]** area.

- 3 Select **[+R1R2]/[+L1L2]** or **[+R1R2]/[+L1L2]** from the **[Orientation:]** list.

Reference

p.33 "Specifying Original Orientation and Setting Originals"

- 4 When the originals are placed in the ADF, select **[Simplex]** or **[Duplex]** in the **[Side:]** list.

Note

- If originals of different sizes are placed in the ADF, press **[Scan Settings]** to specify the document size. If **[Auto detection (Uni-size)]** is selected, all originals are scanned using the size of the first page. If **[Auto detection (Multi-size)]** is selected, all originals are scanned according to their own width. For both Uni-size and Multi-size, all originals are scanned using their own length.

Scanning Originals in Several Times

A large number of originals can be scanned as a single document by dividing them and scanning them individually or in batches using the exposure glass or the ADF. Select **[On]** in **[Job Reset Time in Adding Original]**, and then specify a job reset time. If another original or batch of originals is placed within this time after all previously placed originals have been scanned, it is possible to scan all of these originals as a single document.

Reference

p.19 "Job Reset Time in Adding Original"

- 1 Select **[On]** in **[Job Reset Time in Adding Original]**, and then specify a job reset time in seconds.

Reference

p.19 "Job Reset Time in Adding Original"

- 2 Place the originals.

Reference

p.33 "Placing Originals"

- 3 Make settings for original feed type and original orientation.



Reference

p.37 "Original Orientation and Scan Area"

Note

- When placing originals on the exposure glass, if **[On]** is selected in **[Job Reset Time in Adding Original]**, it is not necessary to select SADF or Batch in **[Original Feed Type]**.

- 4 Make settings for sending by e-mail, delivering, or storing.

Reference

p.45 "Procedure for Sending E-mail"
 p.60 "Delivery Procedure"
 p.72 "Storage Procedure"

When the **[Start]** key is pressed, the originals are scanned.

After the originals are scanned, the remaining time for accepting the next original is displayed.

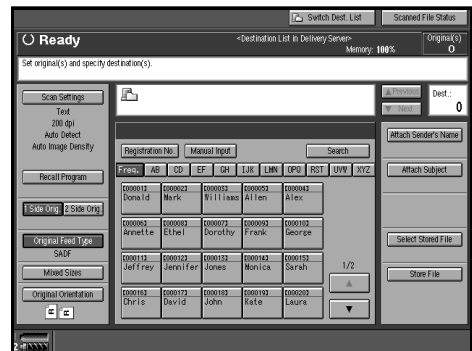

- 5 If you want to change the basic settings, the scanning area, or the original orientation, change the settings before placing the next original.

Note

- While settings are being changed, the countdown until originals are no longer accepted stops.
- Press the **[Start]** key if you want to restart a stopped countdown.

6 When there are other originals to scan, place them within the specified time.

When placed, the originals are fed and scanned automatically.

7 Repeat from step **6** until all originals are scanned.

8 If there are no more originals, press the **[#]** key.

 **Note**

- Originals are scanned in order. Place them from the first page.
- When **[SADF]** is selected and originals are being scanned by dividing them and scanning them consecutively using the ADF, the next original to be added can be placed on the exposure glass to be scanned.

4. Sending Stored Scan Data by E-mail

Stored scan data can be sent to a specified destination using e-mail. This chapter explains the preparation for sending data by e-mail, various display screens, delivery procedures, and how to check the sending result when this function is used.

Preparation for Sending by E-mail

Note

- When an e-mail server is added individually to the network etc., set up the e-mail server. For information about setting up an e-mail server, see the instruction manuals of the e-mail server to be used and the software to be installed.

To send an e-mail, the preparation described below is required.

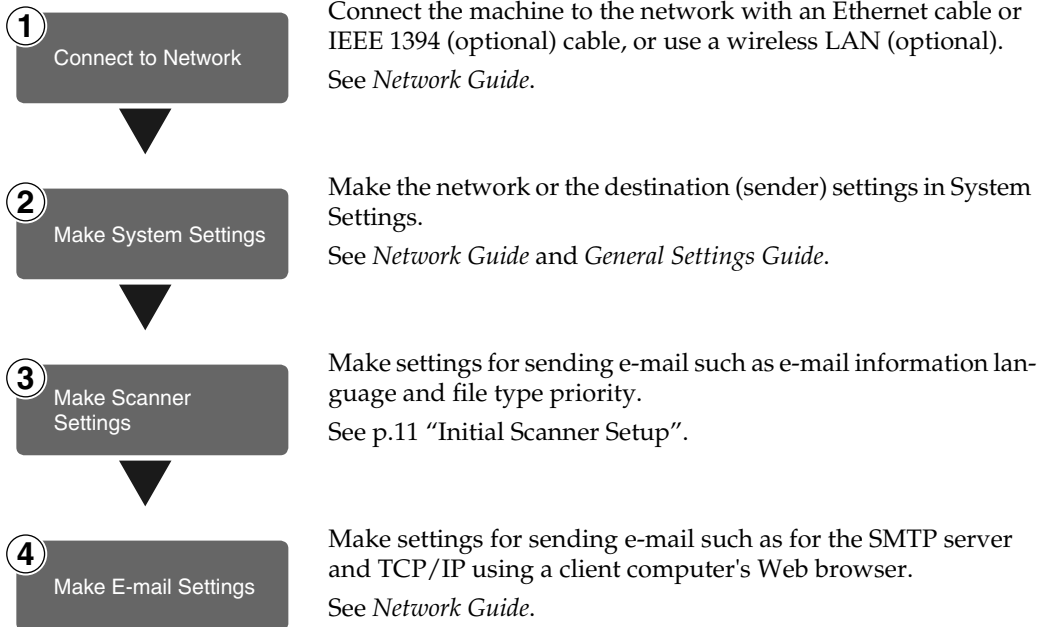

Screen Configuration

The screen configuration when using the machine for e-mail is as shown.

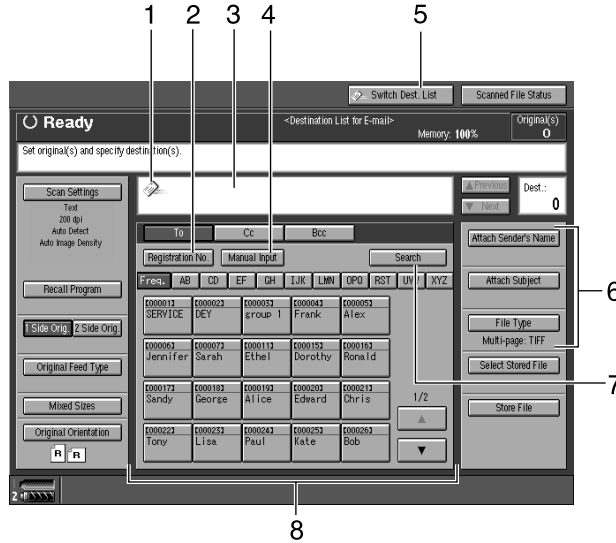

1. E-mail icon (✉)

Displays that the screen for sending e-mail is displayed.

2. [Registration No.]

Press to specify a destination using a five-digit short ID number.

3. Destination field

The selected destination is shown here. If multiple destinations are selected, the destinations are displayed in the order they were selected by pressing [**▲Previous**] or [**▼Next**].

✎ Note

Pressing the [**Check Modes**] key lets you check the selected destinations.

4. [Manual Input]

When specifying a destination that is not listed, press [**Manual Input**], and then enter the destination with the soft keyboard.

5. [Switch Dest. List]

Press to switch a destination from the delivery server list to the destination list of this machine.

6. [Attach Sender's Name] [Attach Subject] [File Type]

Set the sender and the subject of the document to be delivered.

If necessary, select the file type of the image file attached to the e-mail.

7. [Search]

Press to search for an e-mail destination.

8. Destination List

Displays the destinations programmed in the delivery server or this machine.

✎ Note

When the entire list does not fit on one screen, [**▲**] or [**▼**] can be used to scroll through the display.

Group destinations are denoted by this symbol (###).

A bar above a title indicates that a destination that belongs to it has been selected.

Procedure for Sending E-mail

Data is sent after specifying scan settings and the destination.

- 1 Press the **[Scanner]** key.

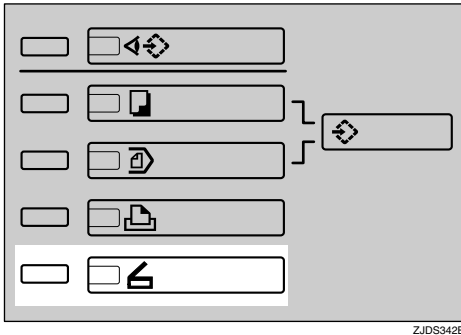

- 2 If user codes are set, enter a user code with the number keys, and then press the **[#]** key.

The Scanner Function screen appears.

Reference

For information about user codes, see *General Settings Guide*.

Note

- If the Network TWAIN Scanner screen appears, press **[Cancel]**.



- 3 Make sure that no previous settings remain.

Note

- If a previous setting remains, press the **[Clear Modes]** key.

- 4 Place the original in the machine, and then adjust the settings for original size and orientation if required.

Reference

p.33 "Setting Originals"

- 5 If the network delivery scanner screen appears, switch to the screen for sending e-mail.

- 1 Press **[Switch Dest. List]**.

The E-mail screen appears.

Note

- If the destination or the sender name is specified, the network delivery scanner screen cannot be switched to the screen for sending e-mail.

- 6 Select the destination.

There are four ways to select a destination: selecting it from the list, selecting it by specifying a short ID number, entering the e-mail address directly, or searching for the destination and selecting it.

Note

- Before selecting the destination, be sure to select **[To]**. When necessary, select **[Cc]** or **[Bcc]** and the respective destinations.
- You can select up to 500 destinations at once.

When selecting a destination from the list

- 1 Press the title for the destination. The destinations for that title are displayed.

If the destination is not displayed, press [▲] or [▼] to display the destination.

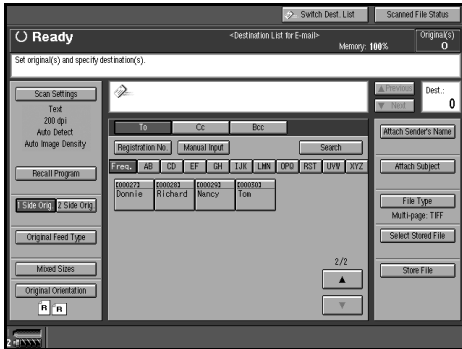

- 2 Select the destination to which the scan data is to be sent.

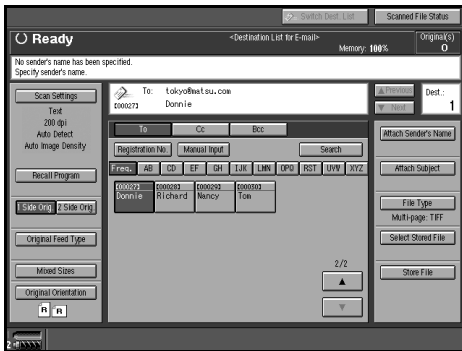

The selected destination is highlighted and also is displayed in the destination field at the top of the screen.

- 3 To select more destinations, repeat step 2.

Note

- To deselect a destination, press the destination once more, or press [▲Previous] or [▼Next] to display the destination in the destination field, and then press the [Clear] key.

Using a short ID number to select a destination

- 1 Press [Registration No.].
- 2 Use the number keys to enter the five-digit short ID number that has been assigned to a destination.

If the entered number is less than five digits long, press the [#] key after the last number.

Example: To enter 00003

Press the [3] key, and then press the [#] key.

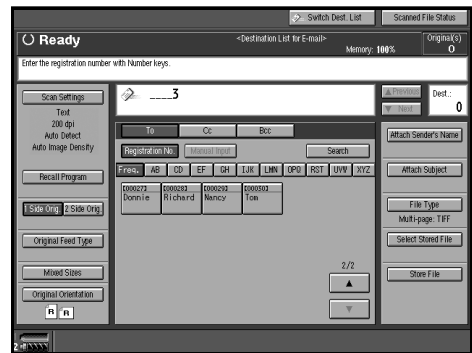

- 3 To select more destinations, repeat steps 1 and 2.

Note

- To deselect a destination, press [▲Previous] or [▼Next] to display the destination in the destination field, and then press the [Clear] key.

Manual entry of an e-mail address

- 1 Press [Manual Input].

The soft keyboard is displayed for entering the e-mail address.

- 2 Enter the e-mail address.

Note

- It is possible to use letters, numbers, and periods. The symbols ()\,;:" cannot be used.

Reference

For information about how to enter characters, see *General Settings Guide*.

③ Press [OK].

Note

- To change the e-mail address that has been entered, press **[Modify]** displayed on the right side of **[Manual Input]**. A soft keyboard for entering the e-mail address is displayed. Make any changes, and then press **[OK]**.
 - Pressing the **[Check Modes]** key on the control panel lets you check the list of selected destinations. To return to the previous screen, press the **[Check Modes]** key again.
- ④ To enter more destinations, repeat steps ① to ③.

Note

- To deselect a destination, press **[▲Previous]** or **[▼Next]** to display the destination in the destination field, and then press the **[Clear]** key.

Searching for a destination to select

There are two ways to search a destination: searching it by destination name or index, or searching it by e-mail address.

① Press [Search].

② Press [Destination Name].

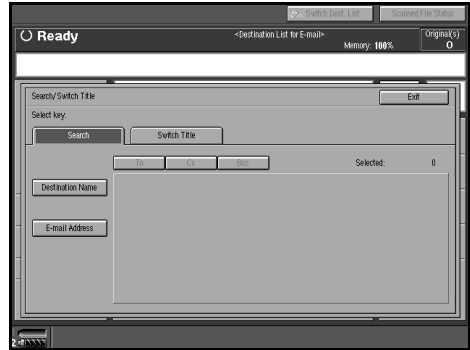

Note

- To search using e-mail addresses, press **[E-mail Address]**. The soft keyboard is displayed for entering a destination name or for entering an e-mail address.

③ Enter the destination name or the e-mail address.

Reference

For information about how to enter characters, see *General Settings Guide*.

Note

- You can also search by entering the first character or characters of the destination name or the e-mail address.
- It is also possible to perform a combined search using **[Destination Name]** and **[E-mail Address]**.
- It is necessary to discriminate between uppercase and lowercase letters.

④ Press [OK].

5 Select a destination.

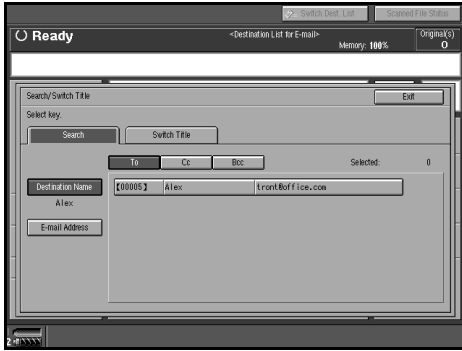

6 Press [Exit].

4

Checking selected destinations

1 Use the destination field at the top of the screen to check which destinations are selected.

Note

- When multiple destinations are selected, the selected destinations are displayed in the order they were selected by pressing [**▲Previous**] or [**▼Next**].
- Pressing the [**Check Modes**] key on the control panel lets you check the list of selected destinations.

7 Make the basic settings.

To make the basic settings, recall stored settings or make the settings individually.

Reference

p.13 “Basic Settings”

Recalling stored scan settings

1 Press [Recall Program].

2 Select a user program of scan settings.

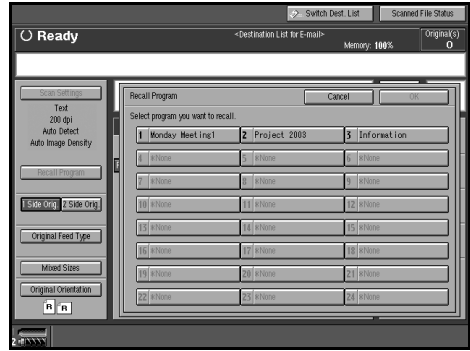

3 Press [OK].

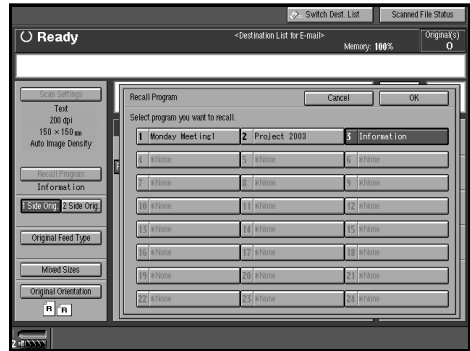

The selected user program settings are applied.

Making the settings individually

1 Press [Scan Settings].

2 Select items such as resolution and original size, and then change their settings.

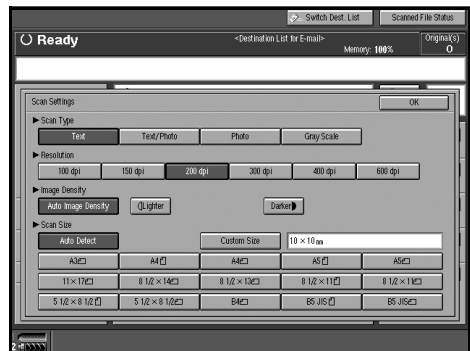

Scan settings can be made in the same way as basic settings. See p.13 “Basic Settings”.

3 Press [OK].

8 Select the file type if necessary.

1 Press [File Type].

2 Select the file type of the file to be attached to the e-mail from the displayed types.

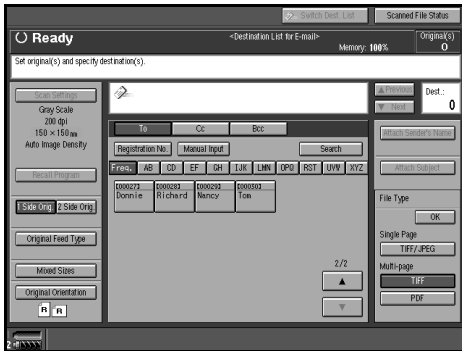

3 Press [OK].

9 Specify the e-mail sender.

There are three ways to select a sender: selecting the sender from the list, entering the five-digit short ID number of the sender with the number keys, and searching for the sender and selecting it.

Note

- When a sender is selected, the sender name is automatically placed in the From field of the e-mail so that the sender can be identified when the e-mail is received.
- To prevent misuse of a sender name, we recommend you set up a password for that sender name.
- Be sure to select or enter a sender name. Otherwise **[Key Operator's E-mail Address]** is used as the sender name. See *General Settings Guide*.

When selecting a sender from the list

1 Press [Attach Sender's Name].



2 Select the sender.

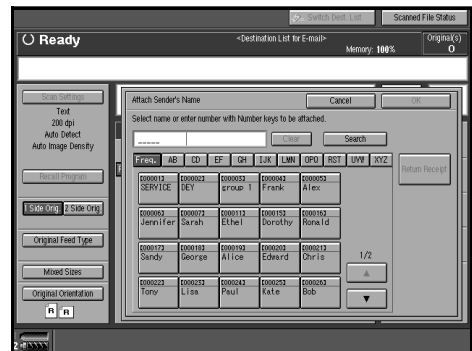

Note

- If a password has been set, a screen for entering the password appears after selecting the sender. Enter the password, and then press [OK]. After verification of the password, the sender name is displayed.

3 For a reception confirmation e-mail, press [Return Receipt].

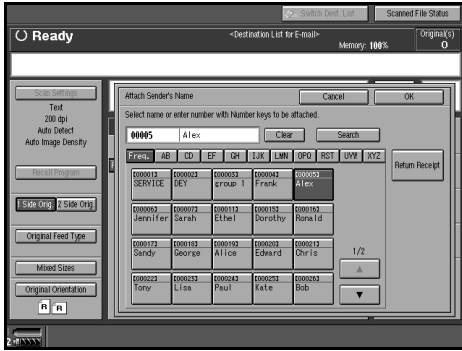

2 Use the number keys to enter the five-digit short ID number that has been assigned to a sender.

If the entered number is less than five digits long, press the [#] key after the last number.

Example: To enter 00006

Press the [6] key, and then press the [#] key.

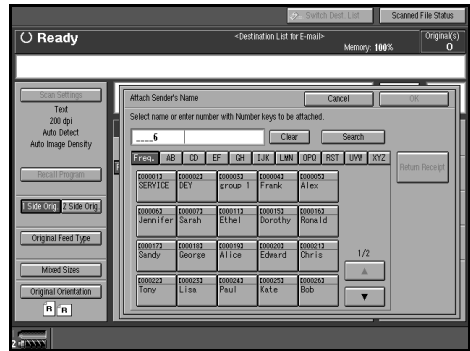

Note

When [Return Receipt] is selected, an e-mail notifying that the e-mail has been read by the destination party is sent to the sender selected here. However, if the mailing software used by the destination party does not support MDN (Message Disposition Notification), the setting in [Return Receipt] becomes invalid.

4 Press [OK].

Note

If a password has been set, a screen for entering the password appears after selecting the sender. Enter the password, and then press [OK]. After verification of the password, the sender name is displayed.

Using a short ID number to specify a sender name

1 Press [Attach Sender's Name].

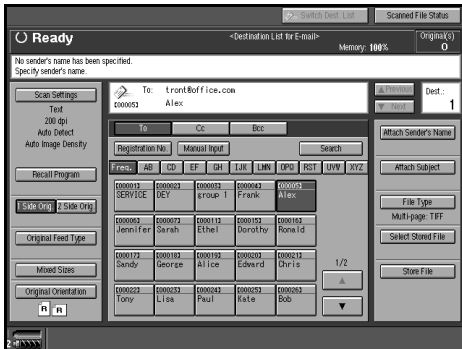

3 For a reception confirmation e-mail, press [Return Receipt].

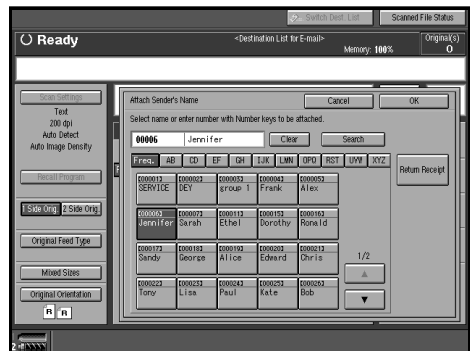

Note

- When **[Return Receipt]** is selected, an e-mail notifying that the e-mail has been read by the destination party is sent to the sender selected here. However, if the mailing software used by the destination party does not support MDN (Message Disposition Notification), the setting in **[Return Receipt]** becomes invalid.

4 Press [OK].

Searching for a sender to select

There are two ways to search a sender: searching it by destination name or index, or searching it by e-mail address.

1 Press [Attach Sender's Name].

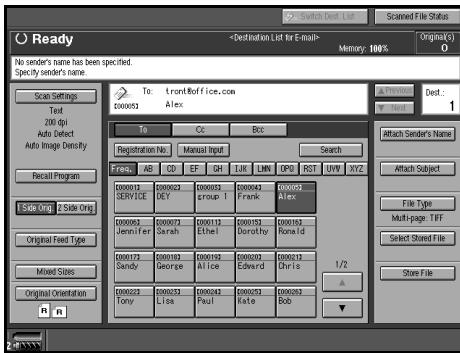

2 Press [Search].

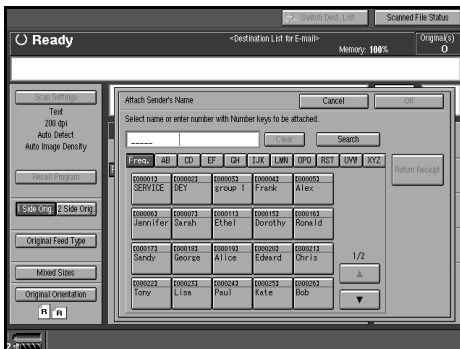

3 Press [Destination Name].

To search using e-mail addresses, press **[E-mail Address]**.

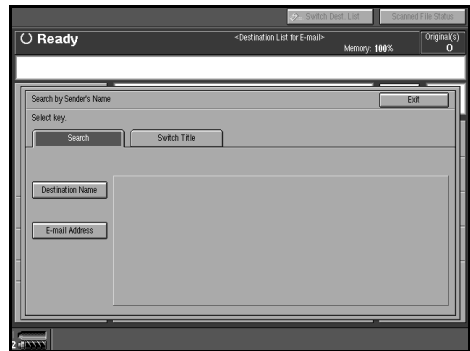

The soft keyboard is displayed for entering a destination name or for entering an e-mail address.

4 Enter the sender name or the e-mail address.

Note

- You can also search by entering the first character or characters of the sender name or the e-mail address.
- It is also possible to perform a combined search using **[Destination Name]** and **[E-mail Address]**.
- It is necessary to discriminate between uppercase and lowercase letters.

Reference

For information about how to enter characters, see *General Settings Guide*.

5 Press [OK].

6 Select the sender.

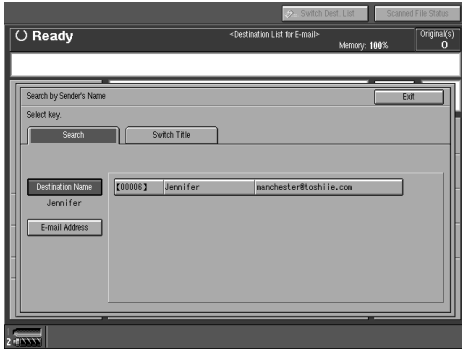

Note

If a password has been set, a screen for entering the password appears after selecting the sender. Enter the password, and then press [OK]. After verification of the password, the sender name is displayed.

7 Press [Exit].

8 For a reception confirmation e-mail, press [Return Receipt].

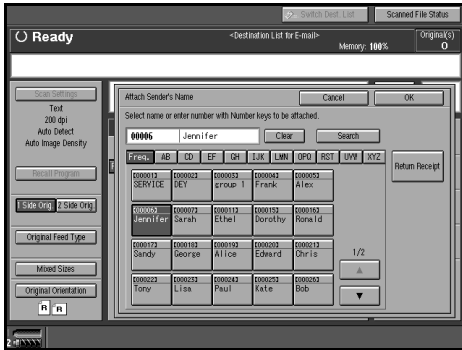

9 Press [OK].

Note

When [Return Receipt] is selected, an e-mail notifying that the e-mail has been read by the destination party is sent to the sender selected here. However, if the mailing software used by the destination party does not support MDN (Message Disposition Notification), the setting in [Return Receipt] becomes invalid.

10 If required, select a subject.

Select a subject from the registered ones. See p.21 "Subject Settings".

Note

The selected subject name is automatically placed in the Subject field of the e-mail. There are two ways to select a subject, selecting it from the list or entering it directly.

When selecting a subject from the list

1 Press [Attach Subject].

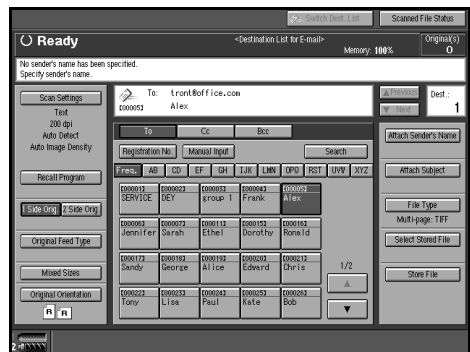

2 Select a subject.

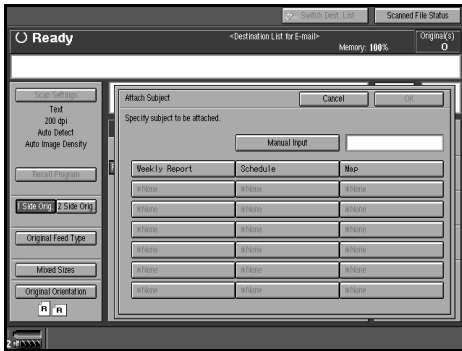

3 Press [OK].

Manual entry of a subject

1 Press [Attach Subject].

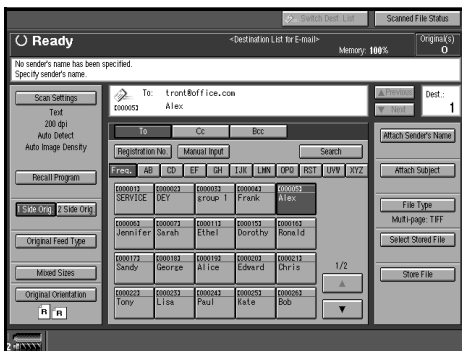

2 Press [Manual Input].

The soft keyboard is displayed for entering a subject.

3 Enter the subject.

Reference

For information about how to enter characters, see *General Settings Guide*.

4 Press [OK] twice.

11 Press the [Start] key.

Note

- To interrupt scanning, press the [Stop] key or press [Stop] on the screen.
- When using the SADP function, place the next original after the others have been scanned. See p.40 "Scanning Originals in Several Times".
- Regardless of the divide e-mail size setting, it is not possible to send e-mail containing a document over 725.3MB. It is also not possible to send a document with more than 2,000 pages.

Simultaneous Storage and Sending of E-mail

You can use e-mail with the Document Server.

Scanned data is stored in the Document Server at the same time the data is sent by e-mail.

Note

- This section explains mainly the operation for simultaneous sending and storage of e-mail. For more information, see p.60 "Delivery Procedure".
- The data stored when simultaneously storing data and sending data by e-mail cannot be resent immediately after it is stored. To resend the data, select the data file in the Select Stored File screen and send it. See p.81 "Sending or Delivering Stored Files".

- 1 Place the original, and then adjust the settings for original size and orientation if required.

Reference

p.33 "Setting Originals"

- 2 Select the destination.
- 3 Make the scan settings.
- 4 Specify the sender (scan data delivery source).
- 5 If required, select a file format and a subject.
- 6 Press [Store File].

- 8 If required, specify a user name, file name, and password for the file to be stored.

Reference

p.73 "Specifying file information"

- 9 Press [OK].
- 10 Press the [Start] key.

4

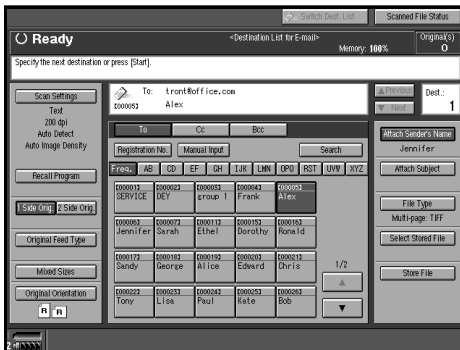

- 7 Make sure [Send & Store] is selected.

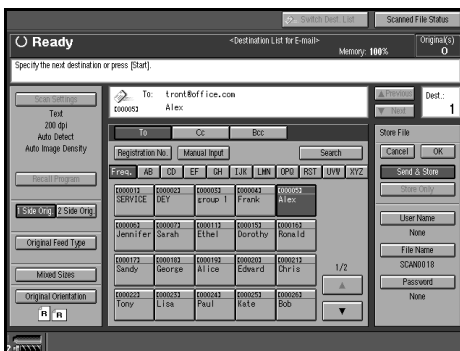

Checking the Status of E-mail

The status of the last 50 e-mails can be checked. For every new e-mail record after 50, the oldest record is deleted.

Note

When **[Print & Delete Scanner Journal]** is set to **[Delete All after Printing]**, the whole journal is printed when the number of records reaches 50.

Items that can be checked

- **Date/Time**
The date and time the e-mail was sent is displayed.
- **Destination**
When multiple destinations were selected, the first selected destination is displayed.
- **Sender**
- **File Name**
- **Status**
Indicates whether the delivery was completed properly, failed, is on standby, or has been suspended.

1 Press **[Scanned File Status]** on the screen for sending e-mail.

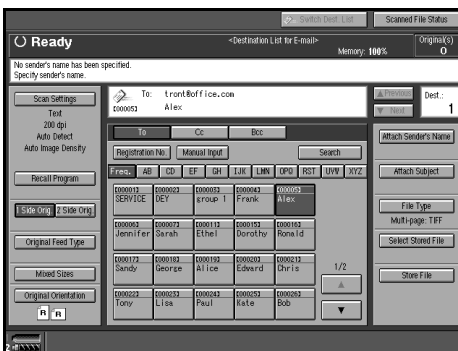

2 Check the displayed records.



Note

- One screen shows the records for 10 delivery operations. Use **[▲Previous]** or **[▼Next]** to scroll through the screen.
- If you select more than 100 destinations for an e-mail, the e-mail will be split into e-mails of 100 destinations at a time with each delivery resulting in a separate e-mail record. For example, if you select 201 destinations, two deliveries of 100 destinations and one delivery of 1 destination will be made resulting in three e-mail records.
- When the status of a document is waiting, the delivery can be stopped by selecting that document, and then pressing **[Cancel Sending]**.

3 Press **[Exit]**.

The display returns to the screen for sending e-mail.

5. Using the Network Delivery Scanner Function

Stored scan data can be sent to a specified destination using the network delivery scanner function. This chapter explains the preparation sequence, various display screens, delivery procedures, and how to check the delivery result when this function is used.

Important

- A delivery server in which ScanRouter V2 Lite/Professional is installed is necessary to use the network delivery scanner function. Information about delivery destinations and senders must be registered first into the delivery server. Also, configure connected devices in **[Set I/O Device]** of ScanRouter V2 Administration Utility. For more information, see ScanRouter V2 Administration Utility Help.

Preparation for Delivering

To use the machine as a network delivery scanner, the preparation described below is required.

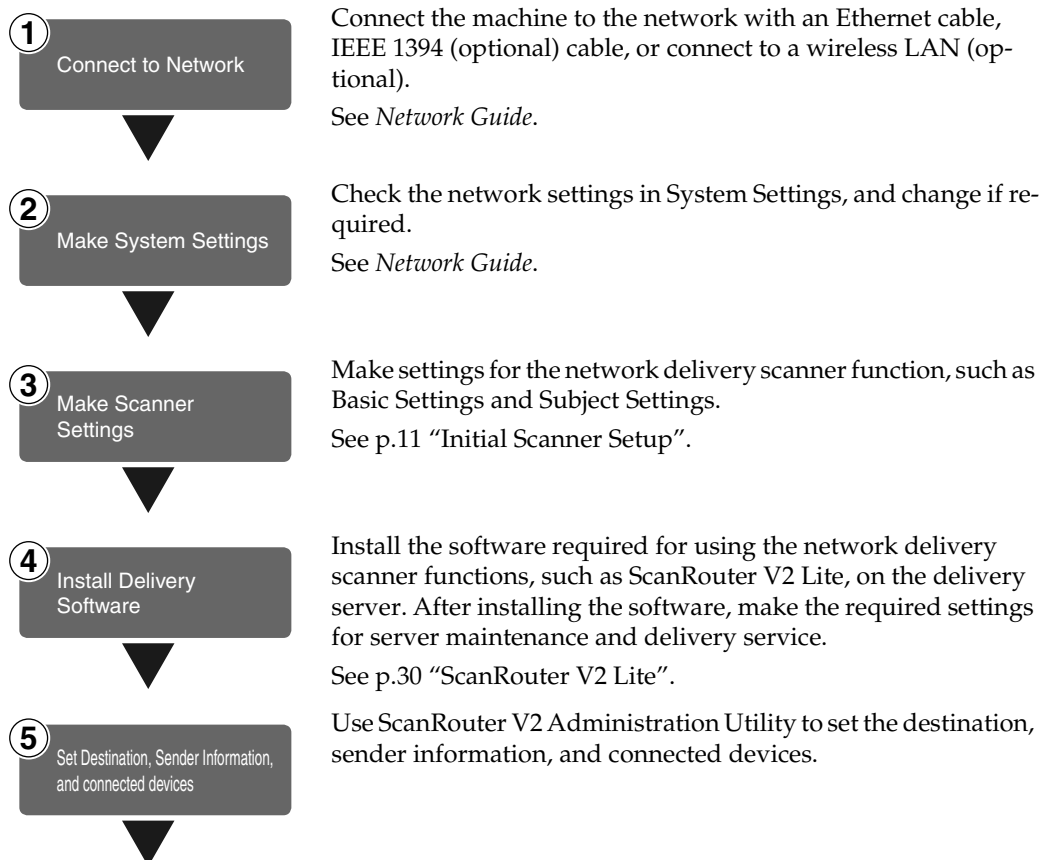

6 Install Client Computer Software

On the client computers, install the software required for viewing or retrieving documents by connecting to the delivery server, such as DeskTopBinder V2 Lite.
See p.27 "DeskTopBinder V2 Lite".

Screen Configuration

The screen configuration when using the machine as a network delivery scanner is as shown.

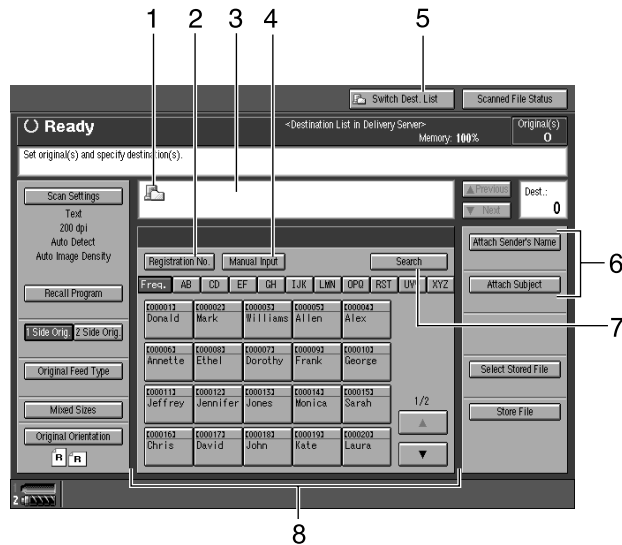

1. Network delivery scanner icon

Shows that the screen for network delivery scanner function is displayed.

2. [Registration No.]

Press to specify a destination using a five-digit short ID number.

3. Destination field

The selected destination is shown here. If multiple destinations are selected, the destinations are displayed in the order they were selected by pressing [▲Previous] or [▼Next].

Note

- Pressing the [Check Modes] key lets you check the selected destinations.

4. [Manual Input]

When specifying a destination that is not listed, press [Manual Input], and then enter the destination with the soft keyboard that is displayed. For information about sending e-mail from the delivery server, see the manual for ScanRouter V2. See p.i "Manuals for This Machine".

5. [Switch Dest. List]

Press to switch a destination list from the delivery server to the destination list of this machine.

6. [Attach Sender's Name] [Attach Subject]

Set the sender and subject of the document to be delivered.

7. [Search]

Press to search for a destination.

8. Destination list

Displays the destinations programed in the delivery server or this machine.

Note

- When the entire list does not fit on one screen, [▲] or [▼] can be used to scroll through the display.
- Group destinations are denoted by this symbol (■ ■ ■).
- A bar above a title indicates that a destination that belongs to it has been selected.

Delivering Stored Scan Data

Delivery Procedure

Data is delivered after scan settings and destination are specified. If necessary, you can select a sender and a subject.

1 Press the **[Scanner]** key.

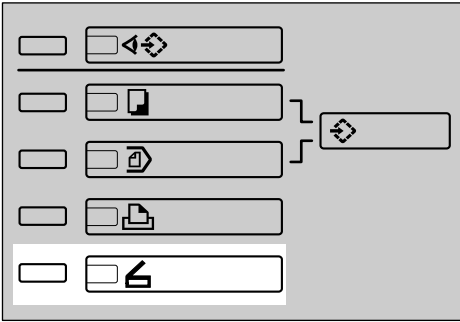

ZJDS342E

2 If user codes are set, enter a user code with the number keys, and then press the **[#]** key.

The Scanner Function screen appears.

Reference

For information about the user codes, see *General Settings Guide*.

Note

- If the Network TWAIN Scanner screen appears, press **[Cancel]**.



3 Make sure that no previous settings remain.

Note

- If a previous setting remains, press the **[Clear Modes]** key.

4 Place the original in the machine, and then adjust the settings for original size and orientation if required.

Reference

p.33 "Setting Originals"

5 If the E-mail screen appears, switch to the screen for network delivery scanner.

1 Press **[Switch Dest. List]**.

The Network Delivery Scanner screen appears.

Note

- If the destination or sender name is specified, the E-mail screen cannot be switched to the screen for network delivery scanner.

6 Select the destination.

There are four ways to specify a destination: selecting it from the list, specifying a short ID number, selecting it after searching for it, or directly typing the e-mail address.

Note

- When using ScanRouter V2 Lite/Professional, the destination list is updated automatically.

When selecting a destination from the list

- 1 Press the title for the destination. The destinations for that title are displayed.

If the destination is not displayed, press [▲] or [▼] to display the destination.

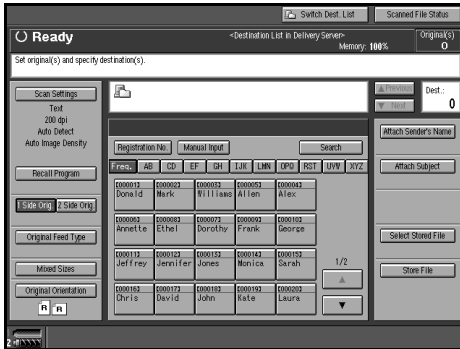

Note

- The destination titles are programmed in the delivery server.

- 2 Select the destination to which the scan data is to be delivered.

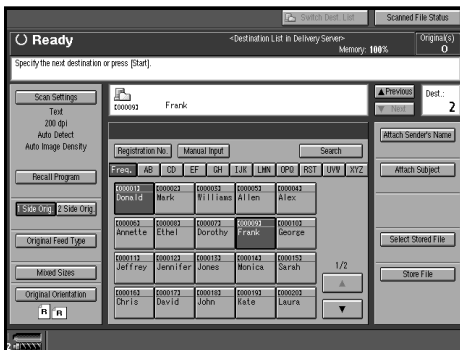

The selected destination is highlighted and also is displayed in the destination field at the top of the screen.

- 3 To select more destinations, repeat step 2.

Note

- To deselect a destination, press the destination once more, or press [▲Previous] or [▼Next] to display the destination in the destination field, and then press the [Clear] key.

Using a short ID number to select a destination

- 1 Press [Registration No.].
- 2 Use the number keys to enter the five-digit short ID number that has been assigned to a destination.

If the entered number is less than five digits long, press the [#] key after the last number.

Example: To enter 00009

Press the [9] key, and then press the [#] key.

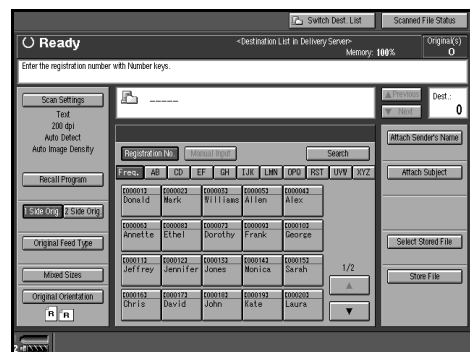

- 3 To select more destinations, repeat step 2.

Note

- To deselect a destination, press [▲Previous] or [▼Next] to display the destination in the destination field, and then press the [Clear] key.

Searching for a destination to select

- 1 Press [Search].
- 2 Press [Destination Name].



5

Note

- When using ScanRouter V2 Professional, it is possible to search by comments.

The soft keyboard is displayed for entering a destination name.

- 3 Enter part of the destination name.

Note

- Enter the first character or characters of the destination name.
- It is necessary to discriminate between uppercase and lowercase letters.

Reference

For information about how to enter characters, see *General Settings Guide*.

- 4 Press [OK].

- 5 Select a destination.

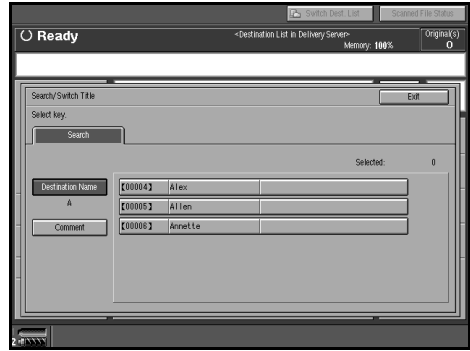

- 6 Press [Exit].

Manual entry of a destination

Note

- When using ScanRouter V2 Professional, it is possible to enter the destination e-mail address directly.

- 1 Press [Manual Input].

The soft keyboard is displayed for entering a destination (e-mail address).

- 2 Enter the destination.

Note

- Enter the e-mail address of the destination when sending via the delivery server.
- It is possible to use letters, numbers, and periods. The symbols ()\,;:" cannot be used.

Reference

For information about how to enter characters, see *General Settings Guide*.

3 Press [OK].**Note**

- Pressing the **[Check Modes]** key on the control panel lets you check the list of selected destinations. To return to the previous screen, press the **[Check Modes]** key again.

4 To enter more destinations, repeat steps **1** to **3**.**Note**

- To deselect a destination, press **[▲Previous]** or **[▼Next]** to display the destination in the destination field, and then press the **[Clear]** key.

Checking selected destinations

1 Use the destination field at the top of the screen to check which destinations are selected.**Note**

- When multiple destinations are selected, the selected destinations are displayed in the order they were selected by pressing **[▲Previous]** or **[▼Next]**.
- Pressing the **[Check Modes]** key on the control panel lets you check the list of selected destinations.

7 Make the basic settings.

To make the basic settings, recall stored settings or make the settings individually.

Reference

p.13 “Basic Settings”

Recalling stored scan settings

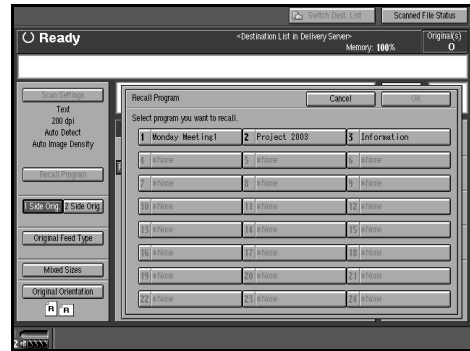
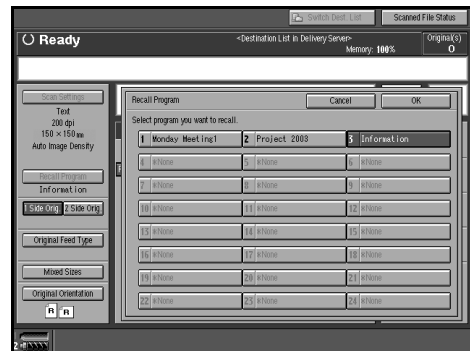
1 Press [Recall Program].**2** Select a user program of scan settings.**3** Press [OK].

The selected user program settings are applied.

Making the settings individually

1 Press [Scan Settings].

- 2 Select items such as resolution and original size, and then change their settings.

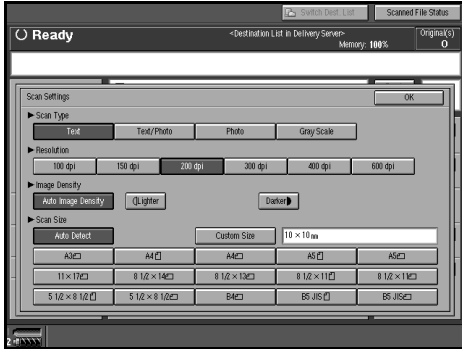

Scan settings can be made in the same way as basic settings. See p.13 “Basic Settings”.

- 3 Press [OK].

- 8 Specify the sender (scan data file delivery source) if necessary.

There are three ways to select a sender: selecting the sender from the list, entering the five-digit short ID number of the sender with the number keys, and searching for the sender and selecting it.

Note

- When a sender has been specified, this information is added to the scan data file. Select a sender from the senders programmed in the delivery server.

When selecting a sender from the list

- 1 Press [Attach Sender's Name].

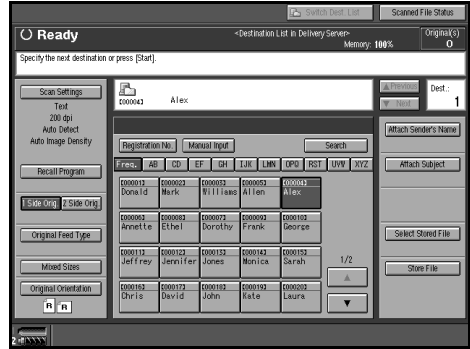

- 2 Select the sender.

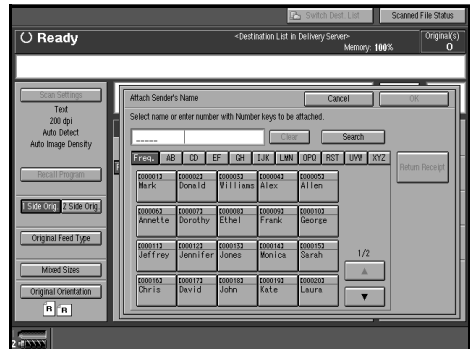

The selected sender and its short ID number are displayed.

Note

- When using ScanRouter V2 Professional, [Return Receipt] is displayed when a sender is selected.

- When **[Return Receipt]** is selected, an e-mail notifying that the document file has been read by the destination party is sent to the sender selected here. To use **[Return Receipt]**, it is necessary to make settings such as e-mail address in advance in ScanRouter V2 Professional.

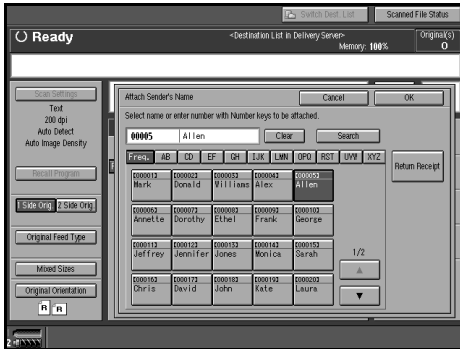

- ③ Press **[OK]**.

Using a short ID number to specify a sender name

- ① Press **[Attach Sender's Name]**.

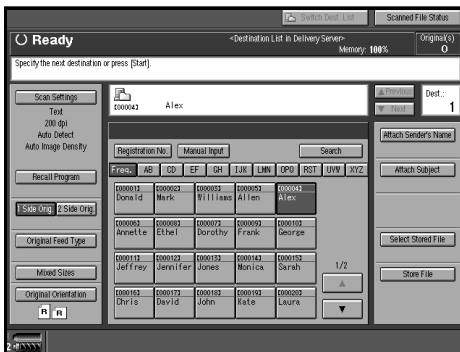

- ② Use the number keys to enter the five-digit short ID number that has been assigned to a sender.

Example: To enter 00006

Press the **[6]** key, and then press the **[#]** key.

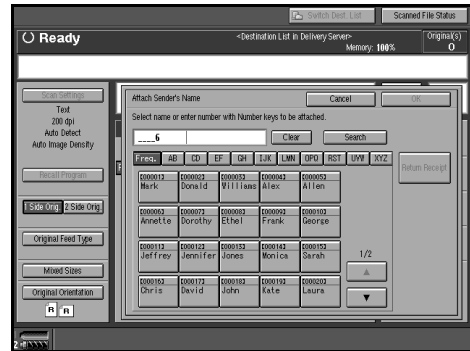

Note

- When using ScanRouter V2 Professional, **[Return Receipt]** is displayed when a sender is selected.
- When **[Return Receipt]** is selected, an e-mail notifying that the document file has been read by the destination party is sent to the sender selected here. To use **[Return Receipt]**, it is necessary to make settings such as e-mail address in advance in ScanRouter V2 Professional.

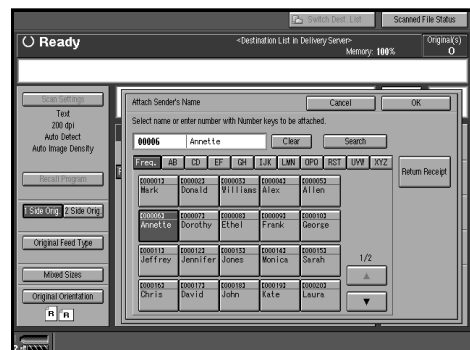

- ③ Press **[OK]**.

Searching for a sender to select

1 Press [Attach Sender's Name].

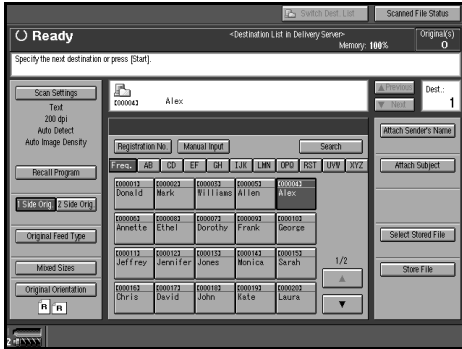

2 Press [Search].

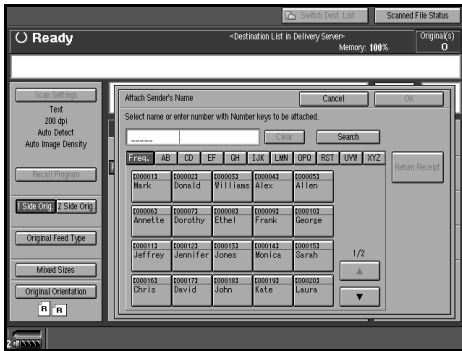

3 Press [Destination Name].

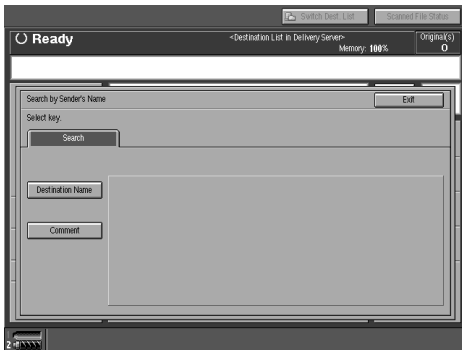

The soft keyboard is displayed for entering a destination name.

4 Enter part of the sender name.

Note

- Enter the first character or characters of the sender name.
- It is necessary to discriminate between uppercase and lowercase letters.

Reference

For information about how to enter characters, see *General Settings Guide*.

5 Press [OK].

6 Select a sender.

7 Press [Exit].

8 Press [OK].

9 If required, select a subject.

Select a subject from the registered ones. See p.21 "Subject Settings".

Note

- When a subject has been specified, this information is added to the scan data file.
- When ScanRouter V2 Professional is used to send documents using e-mail, the subject is automatically entered as the message subject.
- There are two ways to select a subject, selecting it from the list or entering it directly.

When selecting a subject from the list

1 Press [Attach Subject].

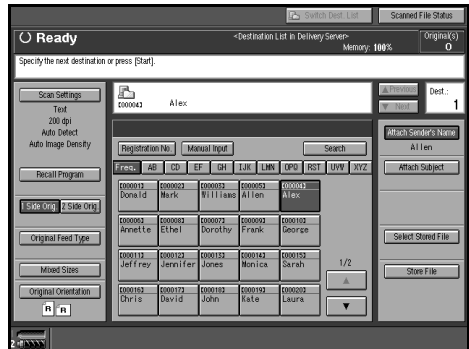

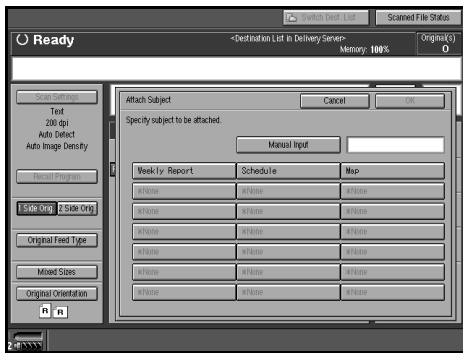
2 Select a subject.**3** Press [OK].

Manual entry of a subject

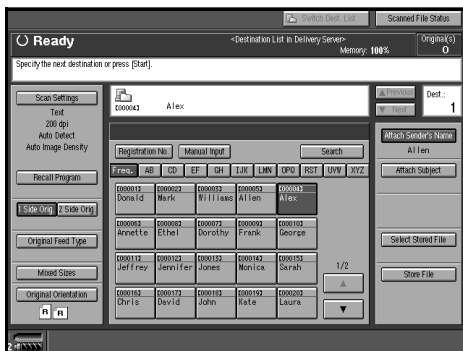
1 Press [Attach Subject].**2** Press [Manual Input].

The soft keyboard is displayed for entering a subject.

3 Enter the subject.**Reference**

For information about how to enter characters, see *General Settings Guide*.

4 Press [OK] twice.**10** Press the [Start] key.**Note**

- To interrupt scanning, press the [Stop] key or [Stop] in the displayed screen.
- When using the SADF or Batch function, place the next original after the others have been scanned. See p.40 "Scanning Originals in Several Times".

Simultaneous Delivery and Storage

You can use the network delivery scanner function with the Document Server.

Scanned data is stored in the Document Server at the same time the data is delivered.

Note

- This section explains mainly the operation for simultaneous delivery and storage. For more information, see p.60 "Delivering Stored Scan Data".

1 Place the original, and then adjust the settings for original size and orientation if required.**Reference**

p.33 "Setting Originals"

2 Make the basic settings.**3** Select the destination.**4** If required, specify the sender (scan data delivery source) and a subject.

5 Press [Store File].

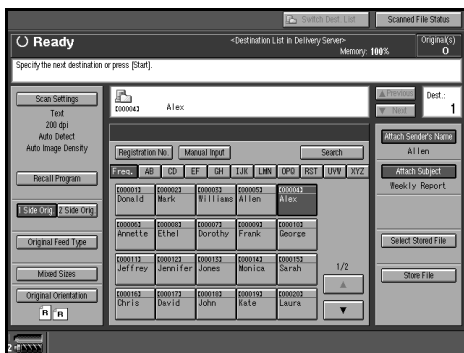

6 Make sure [Send & Store] is selected.

5

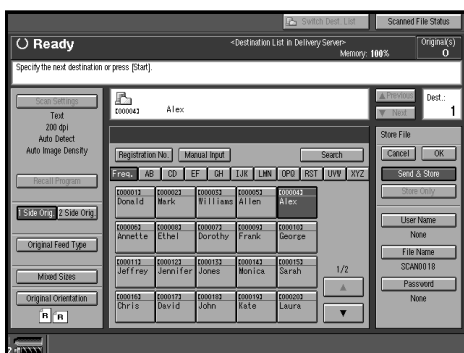

7 If required, specify a user name, file name, and password for the file to be stored.

Reference

p.73 "Specifying file information"

8 Press [OK].

9 Press the [Start] key.

Checking the Status of Delivery

The status of the last 50 deliveries can be checked. For every new delivery record after 50, the oldest record is deleted.

Note

When **[Print & Delete Scanner Journal]** is set to **[Delete All after Printing]**, the whole journal is printed when the number of records reaches 50.

Items that can be checked

- **Date/Time**
The date and time the delivery was requested is displayed.
- **Destination**
When multiple destinations were selected, the first selected destination is displayed.
- **Sender**
- **File Name**
- **Status**
Indicates whether the delivery was completed properly, failed, is on standby, or has been suspended.

1 Press **[Scanned File Status]** on the **Network Delivery Scanner** screen.

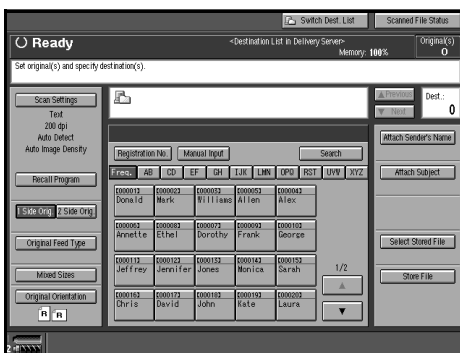

2 Check the displayed records.



Note

One screen shows the records for 10 delivery operations. Use **[▲Previous]** or **[▼Next]** to scroll through the screen. If you select more than 100 destinations for a delivery, the delivery will be split into deliveries of 100 destinations at a time with each delivery resulting in a separate delivery record. For example, if you select 201 destinations, two deliveries of 100 destinations and one delivery of 1 destination will be made resulting in three delivery records.

When the status of a document is waiting, the delivery can be stopped by selecting that document, and then pressing **[Cancel Sending]**.

3 Press **[Exit]**.

The display returns to the **Network Delivery Scanner** screen.

6. Using the Document Server Function

Data obtained by scanning originals can be stored in the hard disk of the machine using the Document Server, and the stored data can be used later. Using DeskTopBinder V2 Lite/Professional, stored data can be viewed, retrieved, or deleted with a client computer. The stored data also can be viewed, downloaded, printed, or deleted using a Web browser from a client computer.

Reference

For more information about using the Document Server, see *General Settings Guide*.

Important

- As the Document Server can be accessed by remote DeskTopBinder users, consider a security system that acts as a protective boundary between your network and external networks if you want to restrict access from outside your network.
- Data stored in the machine might be lost if some kind of failure occurs. The supplier shall not be responsible for any damage that might result from the loss of data. For long-term storage of data, we recommend the use of DeskTopBinder V2 Lite or DeskTopBinder V2 Professional (optional). For more information, please contact your local dealer.

Note

- When a delivery server is added to the network, data stored in the Document Server can be delivered. You can store scanned data in the Document Server and simultaneously deliver it with the network delivery scanner function or send it by e-mail. See p.81 “Sending or Delivering Stored Files”.

Storing Data

This section describes how to store data in the Document Server and how to specify file information for stored data.

Note

- The data stored in the Document Server is deleted automatically after a certain number of days have passed. For information about making settings and changes, see *General Settings Guide*.
- The theoretical maximum number of files that can be stored is 3,000 (2,000 pages per file). However, the actual maximum may be less depending on the space used by the copier function and other functions of the machine.
- Stored documents scanned using the scanner function cannot be printed from the control panel. Print the documents after retrieving them, using DeskTopBinder V2 Lite/Professional.

Storage Procedure

Scan and store the document in the Document Server.

1 Press the **[Scanner]** key.

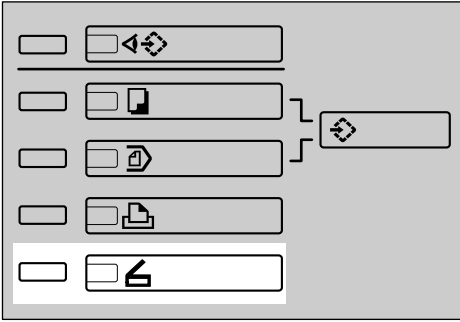

ZJDS342E

2 If the user codes are set, enter a user code with the number keys, and then press the **[#]** key.

The Scanner Function screen appears.

Reference

For information about the user codes, see *General Settings Guide*.

Note

If the Network TWAIN Scanner screen appears, press **[Cancel]**.



3 Make sure that no previous settings remain.

Note

If a previous setting remains, press the **[Clear Modes]** key.

4 Place the original in the machine, and then adjust the settings for original size and orientation if required.

Reference

p.33 "Setting Originals"

5 Make the basic settings.

To make the basic settings, recall the stored settings or make the settings individually.

Reference

p.13 "Basic Settings"

Recalling stored scan settings

1 Press **[Recall Program]**.

2 Select a user program of scan settings.

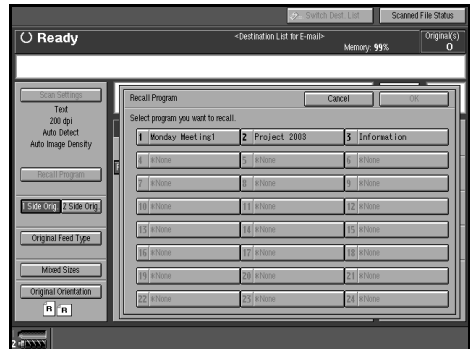

3 Press **[OK]**.



The selected user program settings are applied.

Making settings individually

- 1 Press **[Scan Settings]**.
- 2 Select items such as resolution and original size and change their settings.

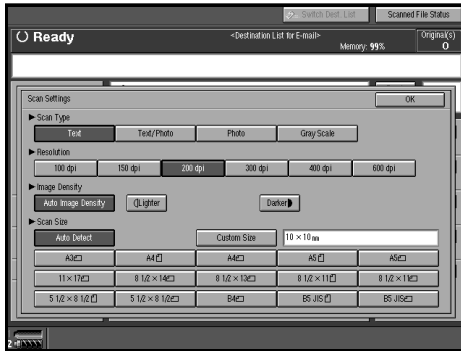

Scan settings can be made in the same way as basic settings. See p.13 “Basic Settings”.

- 3 Press **[OK]**.
- 6 Make the settings for storing scanned data files.

- 1 Press **[Store File]**.

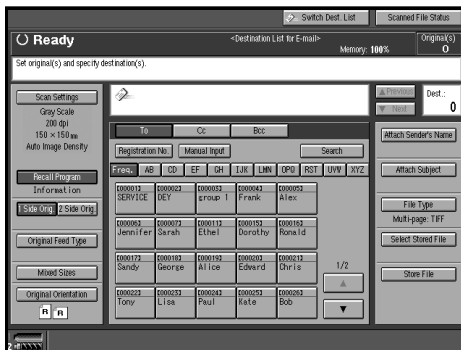

- 2 Press **[Store Only]**.

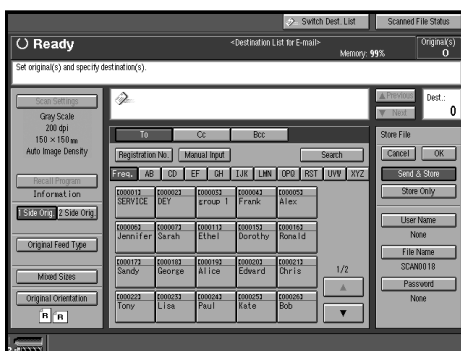

Note

- To store, send by e-mail, or deliver scanned data, press **[Send & Store]**. See p.67 “Simultaneous Delivery and Storage” and p.53 “Simultaneous Storage and Sending of E-mail”.
- [Store Only]** cannot be pressed if even a single destination is selected.

- 7 If required, specify a user name, file name, and password for the file to be stored.

Reference

For more information about how to specify file information, see p.73 “Specifying file information”.

- 8 Press **[OK]**.

- 9 Press the **[Start]** key.

Note

- To abort the scanning process, press the **[Stop]** key or press **[Stop]** on the screen.
- When using the SADF function, place the next original after the others have been scanned. See p.40 “Scanning Originals in Several Times”.

Specifying file information

You can specify a user name, file name, and password for a stored scan data file.

According to the settings made, you can search for files by user name or file name and you can prevent unauthorized persons from accessing the files.

Note

- The file name can be up to 64 characters long. The user name can be up to 20 characters long. The first 16 characters are shown on the control panel. From a client computer with DeskTopBinder V2 Lite/Professional installed, you can view all the characters entered.

1 Display the Store File screen.

1 Press [Store File].

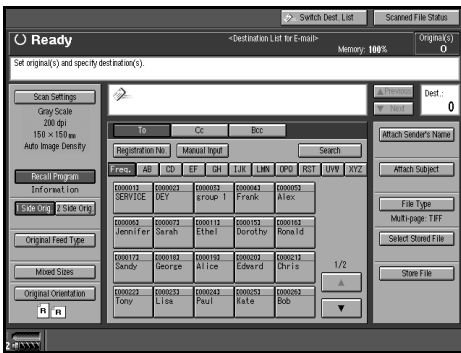

The Store File screen appears.

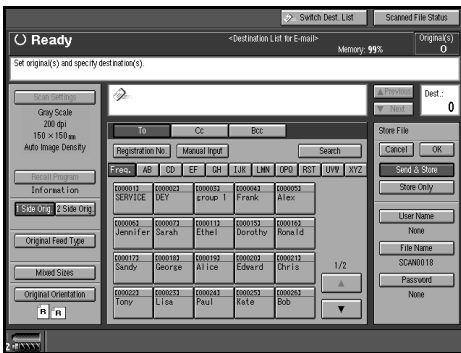

2 Specify file information.

Specifying a user name

1 Press [User Name].

Note

- If no user name is programmed on the Key Operator Tools tab in System Settings, the User Name screen does not appear. Instead, the Non-programmed Name screen appears. Enter the user name.

2 Select the user name.

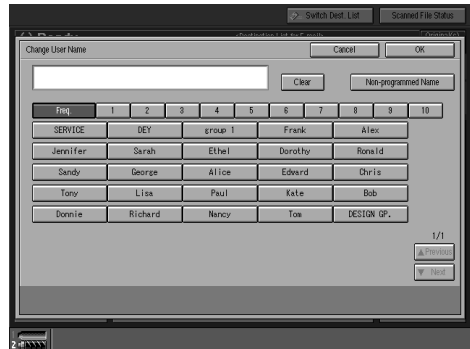

Note

- The user names shown here are names that were programmed on the Key Operator Tools tab in System Settings. To enter a name not shown here, press [Non-programmed Name], and then enter the user name.

3 Press [OK].



Specifying a file name

Scanned data files are automatically named SCAN0001, SCAN0002, etc. If necessary, you can change the file name.

1 Press [File Name].

The soft keyboard is displayed for entering a file name.

2 Enter the file name.

Reference

For information about how to enter characters, see *General Settings Guide*.

3 Press [OK].

3 Press [OK] to return to the previous screen.

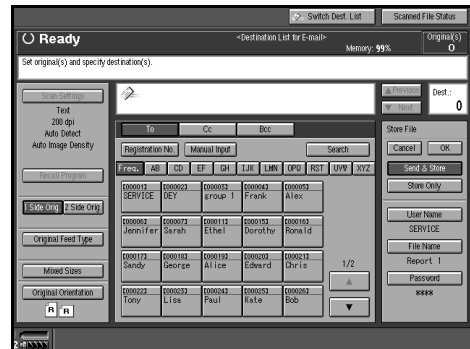

Specifying a password

When a password is specified, only a person who knows the password can view the data.

1 Press [Password].

2 Enter a four-digit password.

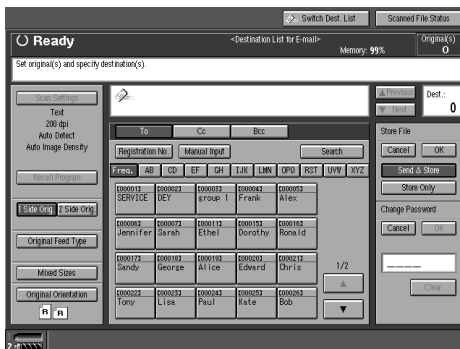

3 Press [OK].

Important

- ❑ Do not forget the password. If you forget it, consult the system administrator of the machine.

Viewing a List of Stored Files

From the list of stored files, you can delete the files stored in the Document Server or change the file information. To show the list of stored files, perform the following steps.

1 Press the **[Scanner]** key.

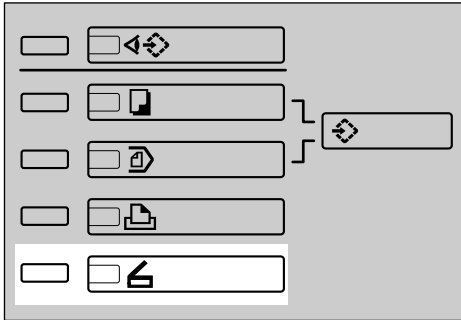

ZJDS342E

6

2 If user codes are set, enter a user code using the number keys, and then press the **[#]** key.

The Scanner Function screen appears.

Reference

For information about the user codes, see *General Settings Guide*.

Note

- ❑ If the Network TWAIN Scanner screen appears, press **[Cancel]**.

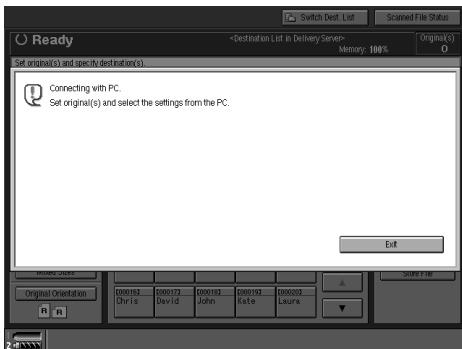

3 Press **[Select Stored File]**.

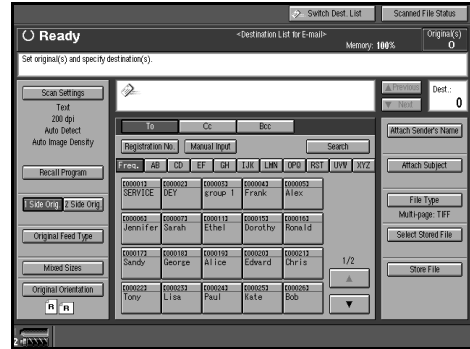

Viewing the List

The list of stored files has the following elements.

❖ When [Manage/Delete File] is selected

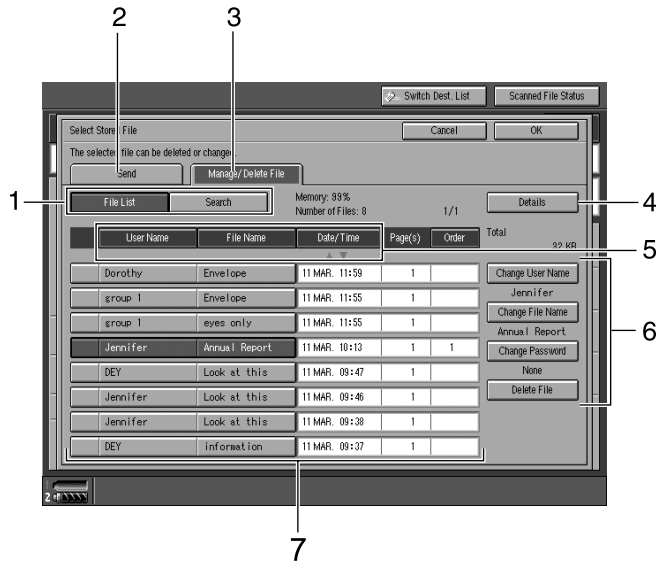

❖ When [Send] is selected

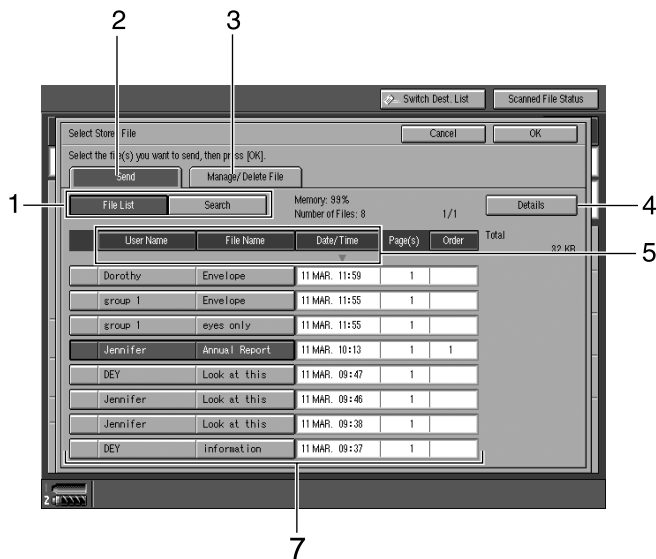

❖ When displaying information of a selected stored file

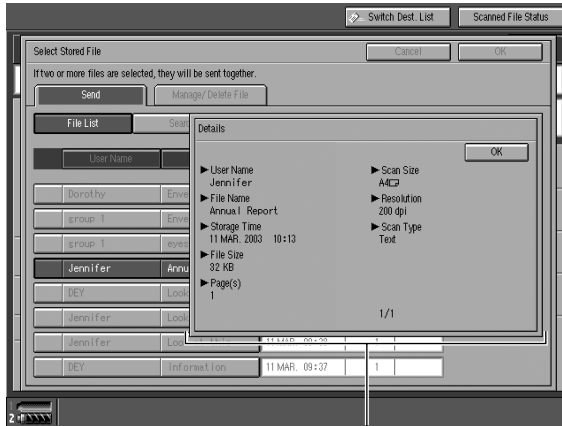

8

1. Keys for searching files

Switch to the screens for searching for a file by user name or file name, or to the screen for displaying all files.

2. [Send]

Press to deliver or send files stored in the Document Server. For more information, see p.81 "Sending or Delivering Stored Files".

3. [Manage/Delete File]

Press to manage or delete files stored in the Document Server or to change file information etc.

4. [Details]

Press to display the detailed information of the selected file.

5. Keys for sorting files (user name/file name/date and time)

Sorts the files using the selected item. Select the same item once more for a reverse sort.

6. Keys for changing file information

Use for deleting the selected file or changing the user name, file name, or password.

7. List of stored files

The list of stored files is displayed.

Note

- Stored files cannot be shown when a function other than the scanning function is being used.
- If the file is not displayed, use [**▲Previous**] or [**▼Next**] to scroll through the list.
- For files which are password protected, a key symbol(Ⓛ) is shown to the left of the file name.

8. Information of a selected stored file

Press [**Details**] to display the information of a file after selecting the file from the file list.

💡 Viewing a list of stored files in DeskTopBinder V2 Lite

The files stored in the Document Server are shown as below when using Desk-TopBinder V2 Lite.

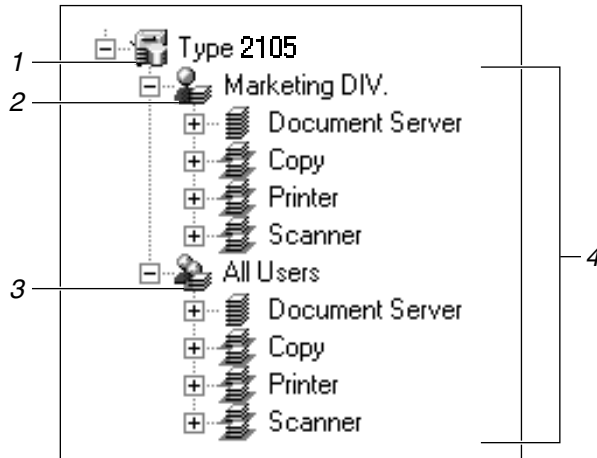

1. Connected device name

The files stored in the connected device are displayed on the desk tree divided into User name and All Users folders.

2. User name

Only the files stored with the same user name specified in the connected device properties are displayed. The files stored from the scanner are shown in the Scanner folder.

3. All Users

All files stored in the connected device are displayed.

4. Folder contents display

The files in the selected folder are displayed.

Searching for Files

You can search for files from the stored files using the user name or file name.

Searching by file name

- 1** On the screen with the list of stored files, press [Search].
- 2** On the search screen, press [Search by File Name].

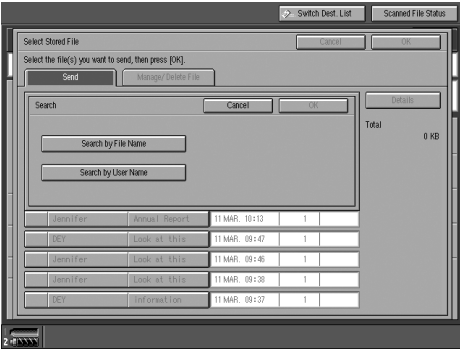

The soft keyboard is displayed for searching by file name.

- 3** Enter the file name to search for.

Reference

For information about how to enter characters, see *General Settings Guide*.

- 4** Press [OK].

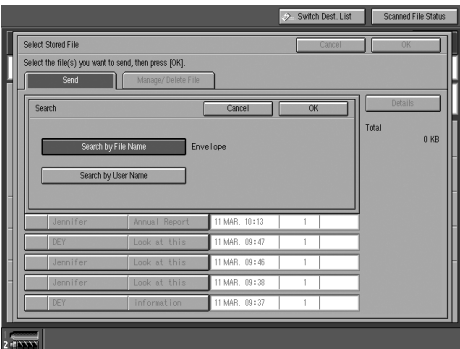

The search starts, and files whose name starts with the entered string are displayed.

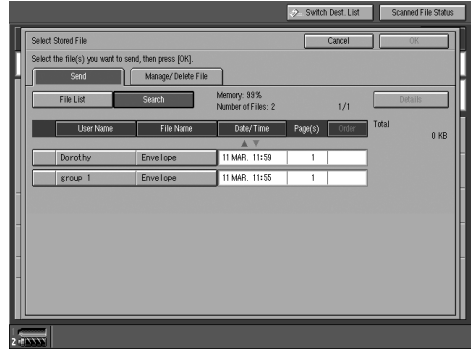

Searching by user name

- 1** On the screen with the list of stored files, press [Search].
- 2** On the search screen, press [Search by User Name].

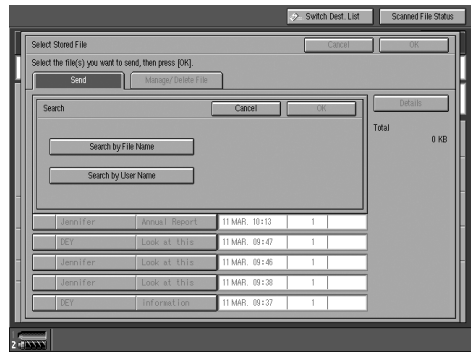

- 3** Select the user name to be used for the search.

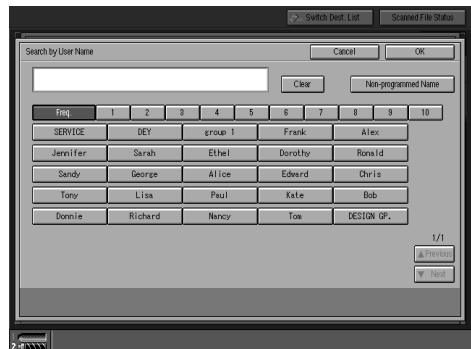

Note

- ❑ The user names shown here are names that were registered on the Key Operator Tools tab in System Settings. To enter a user name not shown here, press **[Non-programmed Name]**, and then enter the name.

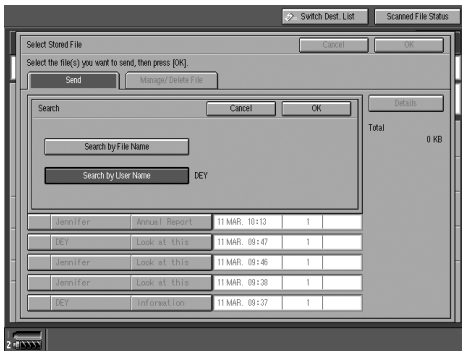
4 Press **[OK]**.

The search starts, and files for which the user name is specified are displayed.

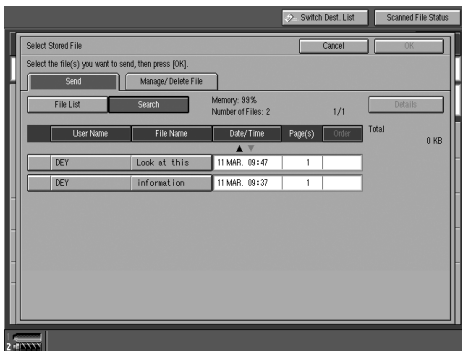

Sending or Delivering Stored Files

Files stored in the Document Server can be sent as e-mail or delivered to the delivery server.

Note

- ❑ This section explains how to select files to be sent or delivered. For more information about sending by e-mail, see p.45 "Procedure for Sending E-mail". For more information about the delivery procedure, see p.60 "Delivery Procedure".

- ❑ When stored files are sent or delivered, basic settings cannot be made. The files are sent or delivered with the basic settings specified when they were stored in the Document Server.

1 Display the list of stored files by pressing **[Select Stored File]**.

Reference

p.76 "Viewing a List of Stored Files"

2 Press the **[Send]** tab.

3 Select a file to be sent or delivered.

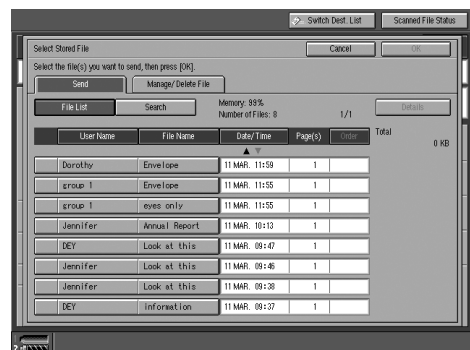

Note

- When you select a password protected file, the Password screen appears. After you have entered the correct password and pressed **[OK]**, the file will be selected.

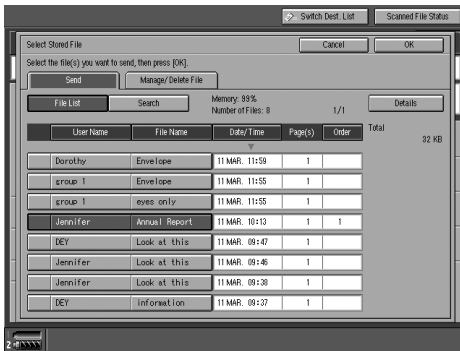
4 To select multiple files, repeat step 3.**Note**

- You can select up to 30 files for one operation.
- If you select multiple files, the files will be sent or delivered in the order they were selected.
- If you press **[Order]**, the selected files will be shown in the order of delivery.

5 Press [OK].

The screen for specifying a destination appears.

6 Switch the Destination List as necessary.**7 Specify a destination.****8 Specify the sender (scan data delivery source).****9 If required, select a file format for sending by e-mail and a subject.****10 Press the [Start] key.**

Managing Stored Files

Displaying and Downloading Stored Files Using a Web Browser

Using a Web browser in a client computer, you can display or download the files in the Document Server. When `http://(machine IP address)/` is entered in the address bar of the Web browser in a client computer, the Stored Files List screen for the Document Server is displayed.

Reference

For displaying or downloading stored files using a Web browser, see *General Settings Guide*.

For more information about making settings for using a Web browser, see *Network Guide*.

For more information about functions for managing stored files, click **[Help]** on the upper-right corner of the displayed screen.

Deleting Files

You can delete files that are no longer needed.

Limitation

- Files waiting for delivery cannot be deleted.

Reference

Using a Web browser (See *General Settings Guide*.) or DeskTopBinder V2 Lite (See DeskTopBinder V2 Lite Help.) from a client computer, you can also delete the files stored in the Document Server.

- 1** Display the list of stored files by pressing **[Select Stored File]**.

Reference

p.76 “Viewing a List of Stored Files”

- 2** Press the **[Manage/Delete File]** tab.

The Manage/Delete File screen appears.

- 3** Select the file to be deleted.

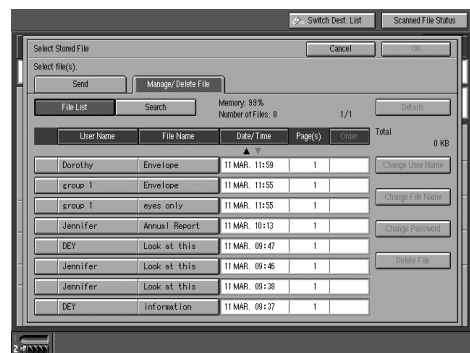

Note

- Up to 30 files can be selected.
- When you select a password protected file, the Password screen appears. Enter the correct password, and then press **[OK]**. When more than one file is selected, the Password screen appears each time a password protected file is selected.

4 Press [Delete File].

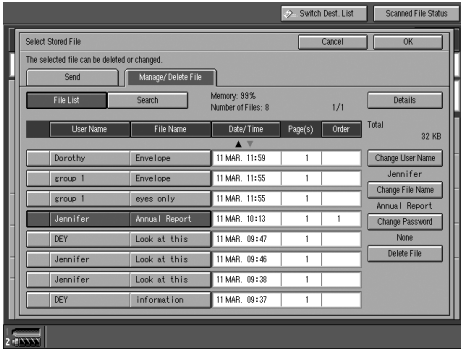

A confirmation message for file deleting appears.

5 Press [Yes].

Changing File Information

The information about files stored in the Document Server (user name, file name, and password) can be changed.

Limitation

- Information about files waiting for delivery cannot be changed.

Reference

Using a Web browser (See *General Settings Guide*.) or DeskTopBinder V2 Lite (See DeskTopBinder V2 Lite Help.) from a client computer, you can change the information of files stored in the Document Server.

1 Display the list of stored files by pressing [Select Stored File].

Reference

p.76 "Viewing a List of Stored Files"

2 Press the [Manage/Delete File] tab.

3 Select the file for which you want to change the file information.

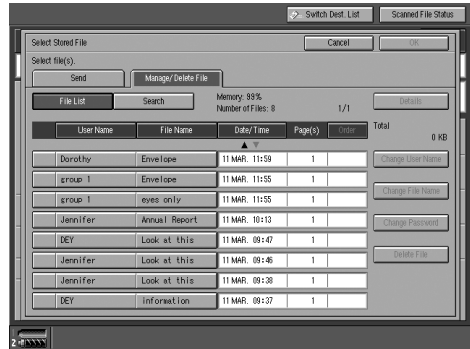

Note

- When you select a password protected file, the Password screen appears. Enter the correct password, and then press [OK].

4 Change the file information.

Changing the user name

1 Press [Change User Name].

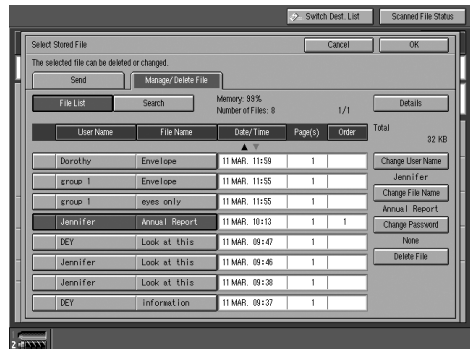

2 Select the new user name.



Note

- The user names shown here are names that were registered on the Key Operator Tools tab in System Settings. To enter a user name not shown here, press **[Non-programmed Name]**, and then enter the user name.

3 Press **[OK]**.



Changing the file name

1 Press **[Change File Name]**.

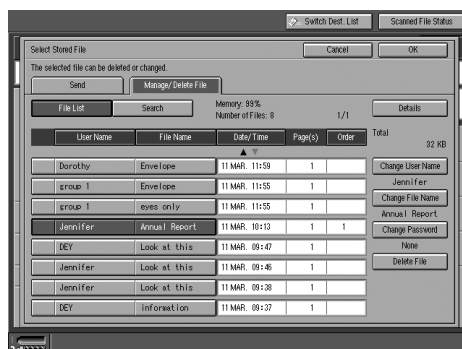

The soft keyboard is displayed for changing the file name.

2 Enter the new file name.

Reference

For information about how to enter characters, see *General Settings Guide*.

3 Press **[OK]**.

Changing the password

1 Press **[Change Password]**.

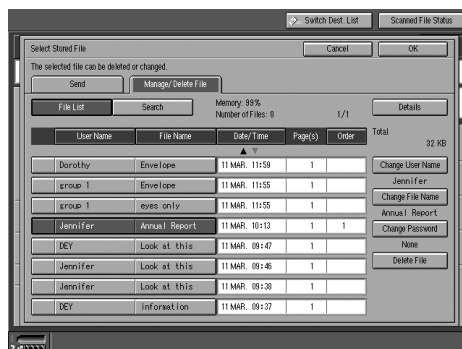

2 Enter a new four-digit password.

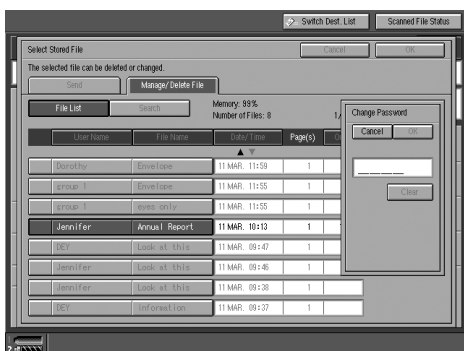

3 Press [OK].

Important

- Do not forget the password. If you forget it, consult the system administrator of the machine.

6

5 Make sure that the file information was changed as necessary, and press [OK].

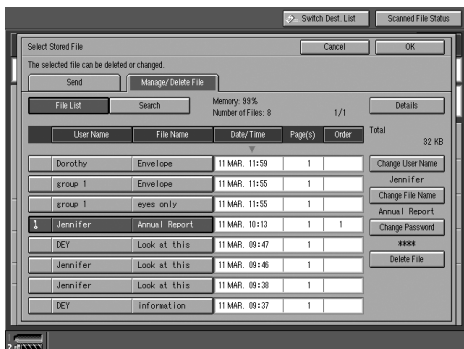

7. Using the Network TWAIN Scanner Function

This chapter describes the operations for scanning originals with the network TWAIN scanner using DeskTopBinder V2 Lite. In addition, the preparation for using the network TWAIN scanner and some functions of the TWAIN driver are introduced.

Preparation for Using the Network TWAIN Scanner

To use the machine as a network TWAIN scanner, the preparation described below is required.

①
Connect to Network

Connect the machine to the network with an Ethernet cable, IEEE 1394 (optional) cable, or use a wireless LAN (optional).
See *Network Guide*.

②
Make System Settings

Check the network settings in System Settings, and change if required.
See *Network Guide*.

③
Install Software

On the client computers, install the software required for using the network TWAIN scanner functions, such as a TWAIN driver and DeskTopBinder V2 Lite.
See p.25 “Software for Using a Network TWAIN Scanner”.

Scanning Originals

This section explains how to scan originals using the network TWAIN scanner function.

1 Start DeskTopBinder V2 Lite, and then select the scanner driver.

1 On the [Start] menu, point to [Program], point to [DeskTopBinder V2], and then click [DeskTopBinder V2].

2 Click [Scanner Settings] on the [Tools] menu.

If the scanner is already selected, no scanner settings are necessary. Check the settings in the [File format for scanned image(s)] area, and then proceed to step

5.

3 Click [Select Scanner Driver].

4 Select the name of the machine you want to use in the list, and then click [Select].

5 Click [OK].

2 Place the original in the scanner.

 **Reference**

p.33 "Setting Originals"

3 Make the basic settings.

1 On the [File] menu, point to [Add Document], and then click [Scan].

The TWAIN driver starts.

After a short while, the dialog box of the TWAIN driver that operates the scanner appears. This dialog box is called the Scanner Properties dialog box.

Note

The name of the scanner currently being used is shown on the title bar of the dialog box. When multiple machines are connected, make sure that the indicated machine is the machine you want to use. If it is different, click [Select Source] to select the scanner again.

If the machine you want to use is not displayed in the list, make sure that the IP address is configured and that the machine is correctly connected to the network. If the machine is still not displayed in the list after confirming the above, consult with your network administrator.

2 Depending on the type of original or the objective for scanning, click the appropriate button in [Mode].

- [Standard] is suitable for scanning standard originals that are comprised of mainly text.

- [Photo] is suitable for scanning originals that include photos, shaded illustrations, etc.

- [OCR] is suitable for conversion processing with an OCR (Optical Character Reading) application after scanning the original.

- [Filing] is suitable for use with filing applications, etc.

 **Note**

- For advanced settings, click **[Detail]** to display the Detail window. For information about the Detail window, see TWAIN driver Help.

- 3** According to the settings of **[Document:]** and **[Orientation:]**, change the other setting of the **[Document]** group.

 **Reference**

p.39 "For a Network TWAIN Scanner"

For information about making settings for the **[Document]** group, see TWAIN driver Help.

When you want to configure the scanning area

When you do not configure the scanning area, the area scanned is the size specified in the **[Size:]** box.

- 1** Click **[Preview]**.

The original that was placed is scanned and the **[Preview]** dialog box appears. The scanning area in the preview is displayed within the broken lines.

- 2** Configure the scanning area by dragging a border or a corner.

When reconfiguring the area, click  and drag one corner of the area towards or away from its opposite corner.

 **Note**

- Depending on the scanning resolution, the area to be scanned may be subject to restrictions.

- 3** Click **[Close]**.

 **Note**

- If the original preview is displayed, a network TWAIN scanner cannot be used from other client computers or other scanner functions until pressing **[Scan]** or **[Close]**.

- 4** Click **[Scan]**.

When there is another original to scan, place the original, and then click **[Continue]**. When there are no more originals, click **[Complete]**.

- 5** Save the scanned image in DeskTopBinder V2 Lite.

- 1** On the **[File]** menu, click **[Exit]**.

- 2** Enter the file name, and then click **[OK]**.

The image is stored in DeskTopBinder V2 Lite, and DeskTopBinder Viewer closes.

Editing and printing scanned data

With DeskTopBinder V2 Lite, it is possible to edit and print scanned data. For more information about how to edit and print, see DeskTopBinder V2 Lite Help.

Functions of the TWAIN Driver

The following is an introduction to the various functions of the TWAIN driver:

Reference

For more information about these functions or other functions, see TWAIN driver Help.

❖ **Automatic Tilt Correction**

This function automatically corrects character strings that were scanned slanted.

❖ **Printing to the Image**

This function allows you to imprint dates, page numbers, or your favorite characters on a scanned image. You can also change the fonts of the imprints as well as change the ascending order of images to a descending order.

❖ **Scanning Mode Registration**

This function allows you to register other scanning configurations that are often used as scanning modes besides the already pre-installed ones. After registration, you can quickly scan with these scanning configurations.

Relationship between Resolution and Data Size

Resolution and scan area are inversely related. The higher the resolution is set, the smaller the area that can be scanned. Conversely, the larger the scan area, the lower the resolution that can be set.

The relationship between the scanning resolution and the data size is shown below. If the data size is too large, the message "Exceeded max. data capacity. Check the scanning resolution." appears on the control panel of the machine. Specify the scan size and resolution again.

❗ Limitation

- Depending on the image compression level, the maximum image size will be limited.

When Using for E-mail, or as a Network Delivery Scanner, or Document Server

❖ When Text, Text/Photo, or Photo is selected as the Scan Type

All combinations up to A3/297 × 432 mm (11 × 17 inches) and 600 dpi are possible.

❖ When Gray Scale is selected as the Scan Type

The originals can be scanned using combinations marked with ○ in the table.

	100 dpi	150 dpi	200 dpi	300 dpi	400 dpi	600 dpi
A3	○	○	○	○		
B4	○	○	○	○	○	
A4	○	○	○	○	○	
B5	○	○	○	○	○	○
A5	○	○	○	○	○	○
B6 *1	○	○	○	○	○	○
A6 *1	○	○	○	○	○	○
A7 *1	○	○	○	○	○	○
11 × 17	○	○	○	○		
Legal (8 ¹ / ₂ × 14)	○	○	○	○	○	
8 ¹ / ₂ × 13	○	○	○	○	○	
Letter (8 ¹ / ₂ × 11)	○	○	○	○	○	
5 ¹ / ₂ × 8 ¹ / ₂	○	○	○	○	○	○

*1 The scanning size must be manually entered.

When Using as a Network TWAIN Scanner

Reference

To specify the scanning area or resolution when using the machine as a network TWAIN scanner, see TWAIN driver Help.

◆ When Binary or Halftone is selected as the Colors/Gradations

The originals can be scanned using combinations marked with ○ in the table.

	100 dpi	200 dpi	300 dpi	400 dpi	500 dpi	600 dpi	700 dpi	800 dpi	900 dpi	1000 dpi	1100 dpi	1200 dpi
A3	○	○	○	○	○	○						
B4	○	○	○	○	○	○						
A4	○	○	○	○	○	○	○	○				
B5	○	○	○	○	○	○	○	○	○			
A5	○	○	○	○	○	○	○	○	○	○	○	○
B6	○	○	○	○	○	○	○	○	○	○	○	○
A6	○	○	○	○	○	○	○	○	○	○	○	○
A7 *1	○	○	○	○	○	○	○	○	○	○	○	○
11x17	○	○	○	○	○	○						
Legal (8 ¹ / ₂ x14)	○	○	○	○	○	○	○					
8 ¹ / ₂ x13	○	○	○	○	○	○	○					
Letter (8 ¹ / ₂ x11)	○	○	○	○	○	○	○	○				
5 ¹ / ₂ x8 ¹ / ₂	○	○	○	○	○	○	○	○	○	○	○	○

*1 The scanning size must be manually entered.

❖ **When Gray Scale is selected as the Colors/Gradations**

The originals can be scanned using combinations marked with ○ in the table.

	100 dpi	200 dpi	300 dpi	400 dpi	500 dpi	600 dpi	700 dpi	800 dpi	900 dpi	1000 dpi	1100 dpi	1200 dpi
A3	○	○	○	○								
B4	○	○	○	○								
A4	○	○	○	○	○	○						
B5	○	○	○	○	○	○						
A5	○	○	○	○	○	○	○	○				
B6	○	○	○	○	○	○	○	○	○			
A6	○	○	○	○	○	○	○	○	○	○	○	○
A7 ^{*1}	○	○	○	○	○	○	○	○	○	○	○	○
11x17	○	○	○	○								
Legal (8 ¹ / ₂ x14)	○	○	○	○	○							
8 ¹ / ₂ x13	○	○	○	○	○							
Letter (8 ¹ / ₂ x11)	○	○	○	○	○	○						
5 ¹ / ₂ x8 ¹ / ₂	○	○	○	○	○	○	○	○				

*1 The scanning size must be manually entered.

Relationship between File Type Specified and File Type Used When Sending E-mail

The relationship between the file type specified when scanning originals and the file type converted into when sending e-mail or storing files is shown below by scan type.

Scan type \ File type	Single page	Multi page	
	TIFF/JPEG	TIFF	PDF
Text (Print)	TIFF	Multi-page TIFF	PDF
Text (OCR)			
Text / Photo			
Photo			
Gray Scale	TIFF (Non-compression) / JPEG (Compression) *1	PDF	

*1 When Gray Scale is used, the file format is converted to JPEG when **[Standard], [High],** or **[Low]** is selected for **[Compression (Gray Scale)]** in **[Scanner Settings]**, and TIFF when **[Off]** is selected.

 **Note**

- Stored documents are saved in single-page style. When sending stored documents by e-mail, you can select single-page style or multi-page style.
- When multi-page TIFF is specified for the documents saved in JPEG format, they are automatically changed to PDF format.

Troubleshooting

This section contains advice on what to do if you have problems scanning an original, or if the network delivery scanner or e-mail function does not work. Various messages that may appear on the control panel or client computer are listed, along with causes and solutions.

When Scanning Is Not Performed as Expected

Problems	Causes and solutions
No image results from scanning.	The original was placed with the front and back reversed. When the original is placed directly on the exposure glass, the side to be scanned must face down. When the original is fed via the ADF, the side to be scanned must face up. See p.33 "Setting Originals".
The image is distorted or out of position.	<ul style="list-style-type: none"> • The original was moved during scanning. Do not move the original during scanning. • The original was not pressed flat against the exposure glass. Make sure that the original is pressed flat against the exposure glass.
The scanned image is upside down.	The original was placed upside down. Place the original in the correct orientation. See p.33 "Setting Originals".
The scanned image is dirty.	The exposure glass or the exposure glass cover is dirty. Clean these parts. See <i>General Settings Guide</i> .

When the Delivery Function Does Not Work

Problems	Causes and solutions
The delivery scanner function screen is not displayed.	<ul style="list-style-type: none"> • If the network TWAIN scanner screen appears when the machine is switched to scanner mode, press [Cancel] to switch to the network delivery scanner screen. • If the display does not switch from network TWAIN scanner to network delivery scanner, the delivery scanner settings are not correct. See p.11 "Default Settings", and then make the appropriate settings.



When an Error Message Appears on the Control Panel

 **Note**

- ❑ If an error message that is not included in this section appears, turn off the main power switch of the machine, and then turn it on again. If the message still appears, note the content of the message and the error number (if listed in the table), and contact your service representative. For information about how to turn off the main power switch, see *General Settings Guide*.

Message	Causes and solutions
Cannot cancel sending all selected file(s). Check [Scanned File Status] to confirm the result.	Only files in waiting can be canceled. Files with a delivery status of successful or other result cannot be canceled.
Cannot communicate with the delivery server. Check the server status.	<p>There is no response from the delivery server. Possible causes are as follows:</p> <ul style="list-style-type: none"> • The delivery server is not running or has not started delivery service. • The delivery server IP address is not set correctly in System Settings. • The delivery server does not recognize the connected device. Register the connected device in Set I/O Device of ScanRouter V2 Administration Utility. See ScanRouter V2 Administration Utility Help. • The machine may not be correctly connected to the network. Check the LED indicators of the Ethernet board. See <i>Network Guide</i>.
Cannot communicate with the SMTP server. Check the server status.	<ul style="list-style-type: none"> • Check whether this machine and the SMTP server are correctly connected to the network. • The SMTP server is not running or is not in service. • Check whether the settings for Network in System Settings are correct.
Cannot delete all selected file(s). Certain file(s) are currently in use.	A file that is being edited with DeskTopBinder V2 Lite/Professional or that is waiting for delivery cannot be deleted. Try the operation again after editing is finished or delivery is canceled.

Message	Causes and solutions
<p>Cannot detect original size. Select a scan size.</p> <p> Note</p> <p><input type="checkbox"/> These messages appear alternately.</p>	<ul style="list-style-type: none"> • Place the original correctly. • Specify the scan size. • When placing an original directly on the exposure glass, the lifting/lowering action of the ADF triggers the automatic original size detection process. Lift the ADF by more than 30 degrees.
<p>Cannot find the SMTP server. Check DNS or SMTP.</p>	<ul style="list-style-type: none"> • Check whether this machine and the e-mail server are correctly connected to the network. • The e-mail server is not running or is not in service. • Check whether the Network settings in System Settings are correct.
<p>Cannot specify more than 500 destinations at the same time.</p>	<p>When there are 500 or more destinations for a delivery or an e-mail, split the destinations into two or more groups.</p>
<p>Cannot specify more than 30 destinations at the same time.</p>	<p>To deliver more than 30 stored files, divide the files and perform the operation several times.</p>
<p>Exceeded max. data capacity. Check the scanning resolution, then press [Start] again.</p>	<p>Specify the scan size and resolution again. Note that it may not be possible to scan very large originals at a high resolution. See p.91 "Relationship between Resolution and Data Size".</p>
<p>Exceeded max. data capacity. Check the scanning resolution, then reset 1 original.</p>	<p>Specify the scan size and resolution again. Note that it may not be possible to scan very large originals at a high resolution. See p.91 "Relationship between Resolution and Data Size".</p>
<p>Exceeded max. E-mail size. Complete scan has not been made. Press [Send] to send the current scanned data, or press [Cancel & Delete].</p>	<p>The size of the e-mail exceeded the maximum size possible.</p> <p>Reduce the volume of images and send it again.</p>
<p>Exceeded max. E-mail size. Sending E-mail has been cancelled. Check [Max. E-mail Size] in Scanner Features.</p>	<ul style="list-style-type: none"> • Increase the size of [Max. E-mail Size]. • Set [Divide & Send E-mail] to [Yes (per Page)] or [Yes (per Max. Size)].
<p>Exceeded max. file capacity. Delete unnecessary stored files.</p>	<p>The maximum number of files that can be stored is 3000. Delete unnecessary files.</p>

Message	Causes and solutions
Exceeded max. number of pages per file. Do you want to store the scanned pages as 1 file?	The maximum number of pages per file is 1,000. Specify whether to use the data or not. Scan the pages that were not scanned and store them as a new file.
Exceeded max. number of search results which can be displayed.	Search again after changing the search conditions.
Exceeded max. number of standby files. Try again after the current file is sent.	There are 50 files waiting in the sending queue for the delivery server. Wait until files have been sent.
Exceeded max. page capacity per file. The current scanned data will be sent.	Because the number of pages has reached the maximum number that can be sent, the data up to this point is sent. Scan the remaining pages after transmission.
Memory is full. Cannot scan.	<p>Because of insufficient hard disk space, the first page could not be scanned. Try one of the following measures:</p> <ul style="list-style-type: none"> • Wait for a while, and then retry the scan operation. • Reduce the scan area or scanning resolution. • Delete unneeded stored files.
<p>Memory is full. Delete unnecessary stored files.</p> <p> Note</p> <p><input type="checkbox"/> These messages appear alternately.</p>	There is not enough free hard disk space. Delete unneeded files.
<p>Memory is full. Scanning has been cancelled. Do you want to store the current scanned data?</p> <p> Note</p> <p><input type="checkbox"/> These messages appear alternately.</p>	Because there is not enough free hard disk space in the machine for storing into the Document Server, only some of the pages could be scanned. Specify whether to use the data or not.
Memory is full. Scanning has been cancelled. Press [Send] to send the current scanned data, or press [Cancel & Delete].	<ul style="list-style-type: none"> • Because there is not enough free hard disk space in the machine for delivery or e-mail, only some of the pages could be scanned. Specify whether or not to deliver the data. • Because there is not enough free hard disk space in the machine for delivering or sending by e-mail while storing into the Document Server, only some of the pages could be scanned. Specify whether to use the data or not.

Message	Causes and solutions
No HDD is available for this function. Cannot store. Set original and select the TWAIN settings from the PC.	Files can be scanned with TWAIN by switching to the network TWAIN scanner function.
Out of paper in Tray 1.	Load paper in the tray indicated.
Out of paper. Load one of the following paper sizes. A3☐, B4 JIS☐, A4☐, A4☐...	Load paper of the sizes listed in the message.
<p>Scanner is currently in use by another function. Switch to another function to confirm the status.</p> <p> Note</p> <p>☐ These messages appear alternately.</p>	The machine is using another function such as copying. Retry scanning after the operation with the other function is completed.
Sender's name is not selected. Sending E-mail has been cancelled.	A sender's name should be specified before sending e-mail. Send e-mail after specifying the sender's name.
Sending the data has been cancelled. The selected file(s) contain some deleted file(s). Try again after checking the stored file(s).	After the files were selected, some files were deleted with DeskTop-Binder V2 Lite/Professional. Perform the selection process again.
Sending the data has failed due to insufficient memory in the delivery server.	There is not enough free space on the hard disk of the delivery server. Free up the required amount.
Sending the data has failed due to insufficient memory in the SMTP server.	There is not enough free space on the hard disk of the SMTP server. Free up the required amount.
Sending the data to the delivery server has failed. Check [Scanned File Status] to confirm the result.	<p>While a file was being sent to the delivery server, a network error occurred and the file could not be sent correctly. Try the operation once more.</p> <p>If the message is still shown, the network may be crowded. Consult the network administrator.</p> <p>If multiple files were sent, use the Scanned Files Status screen to check for which file the problem occurred. See p.69 "Checking the Status of Delivery".</p>
Sending the data to the delivery server has failed. The data will be sent later.	While a file was being sent to the delivery server, a network error occurred and the file could not be sent correctly. Wait until delivery is retried automatically after the preset interval. If the delivery fails again, consult the network administrator.

Message	Causes and solutions
Sending the data to the SMTP server has failed. Check [Scanned File Status] to confirm the result.	<p>While a file was being sent to the SMTP server, a network error occurred and the file could not be sent correctly. Try the operation once more.</p> <p>If the message is still shown, the network may be crowded. Consult the network administrator.</p> <p>If multiple files were sent, use the Scanned Files Status screen to check for which file the problem occurred. See p.69 "Checking the Status of Delivery" and p.55 "Checking the Status of E-mail".</p>
Sending the data to the SMTP server has failed. The data will be sent later.	A network error has occurred and a file was not sent correctly to the SMTP server. Wait until delivery is retried automatically after the preset interval. If the delivery fails again, consult the network administrator.
The destination list has been updated. The specified destination(s) or sender's name has been cleared.	<p>A specified destination or sender's name was cleared when the destination list in the delivery server was updated.</p> <p>Specify the destination or sender's name again.</p>
The entered E-mail address is not correct. Please re-enter.	Make sure the e-mail address is correct, and then enter it again.
The entered password is not correct. Please re-enter.	Enter the password again.
The original is left on the exposure glass.	<ul style="list-style-type: none"> • When placing an original on the exposure glass, remove it after scanning. • Remove the original on the exposure glass before scanning originals in the ADF.
The output buffer is full. Sending the data has been cancelled. Please try again later.	Too many files are waiting to be delivered. Please try again after they have been delivered.
The selected file is currently in use. Cannot change the file name.	The name of a file that is being edited with DeskTopBinder V2 Lite/Professional or that is waiting for delivery cannot be changed. Try the operation again after editing is finished or delivery is canceled.

Message	Causes and solutions
The selected file is currently in use. Cannot change the password.	The password of a file that is being edited with DeskTopBinder V2 Lite/Professional or that is waiting for delivery cannot be changed. Try the operation again after editing is finished or delivery is canceled.
The selected file is currently in use. Cannot change the user name.	The user name of a file that is being edited with DeskTopBinder V2 Lite/Professional or that is waiting for delivery cannot be changed. Try the operation again after editing is finished or delivery is canceled.
The specified group contains some invalid destination(s). Do you want to select only valid destination(s)?	The group contains members whose e-mail addresses are not registered. Please check the e-mail addresses of the group and make selection again.
The specified SMTP server is not set correctly. Sending E-mail has been cancelled.	Check whether the Network settings in System Settings are correct.
Updating the destination list has failed. Do you want to try again?	Check whether the delivery server has started operation.
Updating the destination list...Please wait. The specified destination(s) or sender's name has been cleared.	If a destination or sender's name was already selected, re-select it after this message disappears.

When an Error Message Appears on the Client Computer

This section describes the main possible causes and actions for error messages displayed on the client computer when the TWAIN driver is used.

Note

- ❑ If an error message that is not contained in this section appears, turn off the main power switch of the machine, and then turn it on again. If the message is still shown after scanning is performed again, note the content of the message and the error number (if listed in the table), and contact your service representative. For information about how to turn off the main power switch, see *General Settings Guide*.

Message	Causes and solutions
[Cannot connect to the scanner. Check the network Access Mask settings in User Tools.]	The access mask is set. Consult the network or scanner administrator.
[Cannot detect the paper size of the original. Specify the scanning size.]	<ul style="list-style-type: none"> • Place the original correctly. • Specify the scan size. • When placing an original directly on the exposure glass, the lifting/lowering action of the ADF triggers the automatic original size detection process. Lift the ADF by more than 30 degrees.
[Cannot find the scanner. Check if the scanner main power is on.]	<ul style="list-style-type: none"> • Check whether the main power switch of the machine is turned off. • Check whether the machine is connected to the network correctly. • Deselect the personal firewall function of the client computers.
[Cannot find the scanner used for the previous scan. Another scanner will be used instead.]	Check whether the power switch of the previously used scanner is turned on. Reselect the scanner.
[Cannot save to the default file.]	The default file cannot be overwritten. Save the data to another file.
[Error has occurred in the scanner.]	Check whether the scanning settings made with the application exceed the setting range of the machine.
[Error has occurred in the scanner driver.]	<ul style="list-style-type: none"> • Check whether the network cable is connected correctly to the client computer. • Check whether the Ethernet board of the client computer is recognized correctly by Windows. • Check whether your computer can use the TCP/IP protocol.

Message	Causes and solutions
[Failed to create the file.]	There is not enough free space on the hard disk. Delete the unnecessary files.
[Failed to save the preview image.]	There is not enough free space on the hard disk. Delete the unnecessary files.
[Insufficient memory. Close all applications, then restart scanning.]	Close all the unnecessary applications running on the client computer.
[Insufficient memory. Reduce the scanning area.]	<ul style="list-style-type: none"> • Reset the scan size. • Lower the resolution. • Set with no compression. See p.17 “Scanner Settings”. <p> Note</p> <ul style="list-style-type: none"> <input type="checkbox"/> “The Relationship between the Resolution and the Scanning Area” chart in Help for halftone scanning might not always apply. Scanning cannot be performed if large values are set for brightness when using halftone or high resolution. <input type="checkbox"/> When a paper misfeed occurs in the machine during printing, scanning cannot be performed. In this case, after the misfed paper has been removed, proceed with scanning.
[No response from the scanner.]	<ul style="list-style-type: none"> • Check whether the machine is connected to the network correctly. • The network is crowded. Wait for a while, and then try to reconnect.
[No User Code is registered. Consult your system administrator.]	Access is restricted with user codes. Consult the system administrator of the machine.
[Please call your service representative.]	An unrecoverable error has occurred in the machine. Call your service representative.
[Please wait.]	The machine is in warming up. Please wait. Automatic scanning will start soon.
[Scanner is in use for other function. Please wait.]	A function of the machine other than the scanner function is being used such as the copier function. Wait for a while and reconnect.
[Scanner is in use by other user. Please wait.]	Another user is using the machine to scan originals. Wait for a while and reconnect.

Message	Causes and solutions
[Scanner is not available. Check the scanner connection status.]	<ul style="list-style-type: none">• Check whether the main power switch of the machine is turned off.• Check whether the machine is connected to the network correctly.• Deselect the personal firewall function of the client computers.
[Scanner is not ready. Check the scanner and the options.]	Check whether the ADF cover is closed.
[The name is already in use. Check the registered names.]	You tried to register a name that is already in use. Use another name.
[The scanner power is off.]	<ul style="list-style-type: none">• Check whether the main power switch of the machine is turned on.• Check whether the machine is connected to the network correctly.

Specifications

Scan method	Flat bed scanning
Image sensor type	CCD Image Sensor
Scan type	Sheet, book
Interface	Ethernet interface (10BASE-T or 100BASE-TX), IEEE 1394(optional), and wireless LAN(optional)
Maximum scan size	A3/297 × 432 mm (11 × 17 inches)
Scan density	600 dpi
Variable range of scan resolution	<ul style="list-style-type: none"> • When used as a network TWAIN scanner Setting range: 100 dpi - 1200 dpi • When used as a network delivery scanner or for sending e-mail Setting range: 100 dpi, 150 dpi, 200 dpi, 300 dpi, 400 dpi, and 600 dpi
File formats that can be sent by e-mail	TIFF, JPEG, PDF
Mailing protocol	Send: SMTP

INDEX

A

Automatic Tilt Correction, 90
Auto run program, 23

B

Basic Settings, 13

C

Checking the status of delivery, 69
【**Check Modes**】key, 7
【**Clear**】key, 7
【**Clear Modes**】key, 7
Compression (Black & White), 17
Compression (Gray Scale), 17

D

Default settings, 11
DeskTopBinder V2 Lite, 27, 29, 87
Destination List Priority, 18
Display Contents
 E-mail, 9
 Network delivery scanner, 9
 Network TWAIN scanner, 8
Display panel, 8
Divide & Send E-mail, 18
Document Server, 5

E

E-mail, 3
E-mail Information Language, 18
【**Energy Saver**】key, 7
【**#**】Enter key, 7

F

File Type Priority, 19
Function keys, 8
Function status indicators, 8

I

Image density, 13
Indicators, 8
Initial scanner setup, 11
Installing software, 23

J

Job Reset Time in Adding Original, 19

L

List displays
 Stored Files, 77

M

Max. E-mail Size, 18
Mixed Original Sizes Priority, 20
Mode, 88

N

Network delivery scanner, 4
Network TWAIN scanner, 6
Number keys, 7

O

Original Feed Type Priority, 19
Original orientation and scan area, 37
Original Orientation Priority, 20
Original Setting, 19

P

Placing on the exposure glass, 34
Placing original in the Auto Document Feeder (ADF), 35
Preview, 89
Print & Delete Scanner Journal, 20
Printing to the image, 90

R

Relationship between File Type Specified and File Type Used When Sending E-mail, 94
Relationship between resolution and data size, 91
Resolution, 13

S

- Save, 89
- Scanning mode registration, 90
- Scanning originals, 88
- ScanRouter V2 Lite, 30
- Scan size, 13
- Scan type, 13
- Selecting a custom size, 15
- Select Title, 18
- Sender's Name Default, 18
- Send/Store Connection timeout, 17
- Software supplied on CD-ROM, 28
- 【Start】** key, 7
- Status indicator, 7
- 【Stop】** key, 7
- Stored files
 - Searching*, 80
- Storing data, 71

T

- Troubleshooting, 95
- Type2105 TWAIN Driver, 28

U

- Update delivery scanner destination list, 20
- 【User Tools】** key, 8

V

- Viewing a list of stored files in DeskTopBinder V2 Lite, 79

In accordance with IEC 60417, this machine uses the following symbols for the main power switch:

I means **POWER ON.**

⏻ means **STAND BY.**



Declaration of Conformity

“The Product complies with the requirements of the EMC Directive 89/336/EEC and its amending directives and the Low Voltage Directive 73/23/EEC and its amending directives.”

Trademarks

Adobe and Acrobat are trademarks of Adobe Systems Incorporated.

Ethernet is a registered trademark of Xerox Corporation.

Pentium is a registered trademark of Intel Corporation.

MS, Microsoft, and Windows are registered trademarks of Microsoft Corporation.

Other product names used herein are for identification purposes only and might be trademarks of their respective companies. We disclaim any and all rights in those marks.

- The product name of Windows[®]95 is Microsoft[®] Windows[®] 95.
- The product name of Windows[®]98 is Microsoft[®] Windows[®] 98.
- The product name of Windows[®] Me is Microsoft[®] Windows[®] Millennium Edition (Windows Me).
- The product names of Windows[®] XP are as follows:
 - Microsoft[®] Windows[®] XP Professional
 - Microsoft[®] Windows[®] XP Home Edition
- The product names of Windows[®] 2000 are as follows:
 - Microsoft[®] Windows[®] 2000 Advanced Server
 - Microsoft[®] Windows[®] 2000 Server
 - Microsoft[®] Windows[®] 2000 Professional
- The product names of Windows NT[®] are as follows:
 - Microsoft[®] Windows NT[®] Server 4.0
 - Microsoft[®] Windows NT[®] Workstation 4.0

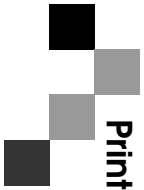

Printer/Scanner Unit Type 2105 Operating Instructions Scanner Reference